

Frese S - dynamic balancing valve

Application

Frese S is used in heating and cooling systems for the distribution of flow in various sections of the system.

The dynamic balancing valve ensures easy and reliable balancing of the system, regardless of any fluctuations in the differential pressure of the system.

Frese S limits maximum flow in the system, and ensures the most economical operation.

Can be used in both variable and constant flow systems.



Benefits

- Quick and easy selection as only flow data are required.
- Security that the specified flow will not be exceeded.
- Easy to install and adjust according to pre-defined flow.
- Flexibility if the system is modified after the initial installation
- Minimized commissioning time due to automatic balancing of the system.
- High comfort for the end-users due to right balance of the hydraulic system.
- The valves automatically find the hydraulic balance regardless of pressure fluctuations in the system.
- No main circuit or branch balancing valves needed in the system.
- Systems with dynamic balancing are flexible, as they do not require readjustment of the "original" circuit in case the system is extended after installation.

Features

- Removable differential pressure cartridge solution simplifies flushing procedure
- No minimum straight pipe lengths required before or after the valve.
- Built-in optional P/T ports for needle system.
- Easy adjustment of the flow by the lockable handle.

Frese S - dynamic balancing valve

Function Frese S

The following applies to all flow control valves:

$$Q = kV \cdot \sqrt{\Delta p}$$

Q = Flow (m³/h)

kV = Opening area

Δp = Differential pressure (Bar)

The Frese S valves, react to pressure fluctuations so that the differential pressure across the preadjustment unit is kept constant. In that way a max. flow limit is ensured in accordance with the design.

Simplified outline S

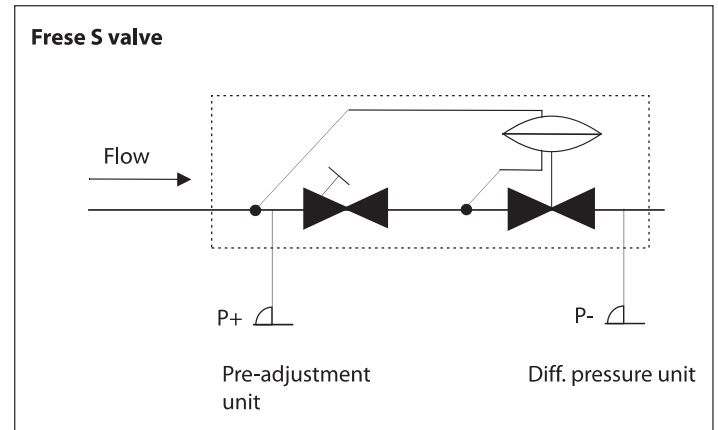

Flow characteristic

The illustration shows how the flow in a Frese S valve reacts in accordance to the pump pressure.

For comparison we have added a typical flow.

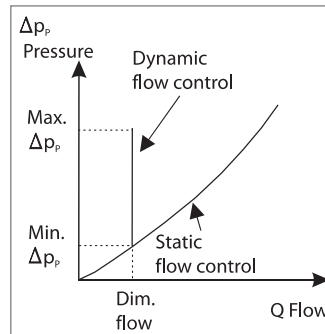

The differential pressure unit of the valve will work as soon as the differential pressure provided by the pump is sufficient. Consequently, the rated flow is maintained regardless of any pressure fluctuations in the system.

Setting the valve

The valve is easily set, and the pre-setting is read on the scale. The flow rate of the valve can be determined from the flow rate graphs for the valve dimension in question.

See the flow rate graphs of the valve on pages 7 to 13 for further information about the adjustment setting.

Please note:

The scale is for the adjustment of flow. If you want to close the valve, use the version with isolation ball valve.

The handle can be locked after adjustment.

Remove cap marked Frese, and tighten with 5mm hexagonal key.



The flow through the valve can be identified by measuring the differential pressure (Δp) across the valve:

If the measured differential pressure is above the minimum Δp, the flow is the one stated on the graph for the valve.

If the measured differential pressure is below the minimum Δp, the flow can be found by using the formulas below.

Flow Calculation

$Q = kV \cdot \sqrt{\Delta p}$	$Q = \text{m}^3/\text{h}$ $\Delta p = \text{Bar}$
$Q = kV \cdot 100 \cdot \sqrt{\Delta p}$	$Q = \text{l}/\text{h}$ $\Delta p = \text{kPa}$
$Q = \frac{kV}{36} \cdot \sqrt{\Delta p}$	$Q = \text{l}/\text{s}$ $\Delta p = \text{kPa}$

Frese S - dynamic balancing valve

Verification of dynamic systems

In general the flow rate in a system can be verified in two ways, i.e.:

- Direct flow rate verification in a circuit
- Measurement of the differential pressure across the balancing valve or metering station.

Direct flow rate verification

Can for example be carried out by ultrasonic equipment. On the basis of the measured velocity of the flow and the pipe dimension the software will compute a flow rate. The use of ultrasonic verification requires free access to the pipes as the sensors are fitted directly to the pipe.

Measurement of the differential pressure is the prevailing method.

On dynamic valves the differential pressure across the valve is measured to determine whether the valve is within the pressure range or not.

Use the flow graphs to set the valve and verify the min. ΔP .

As previously mentioned, the Frese valve includes a differential pressure regulator, to keep the design flow limited under different pressure conditions. The flow rate itself, however, is only determined by the pre-setting in the same way as in a static valve.

Use the procedure as described for verification of the flow, and for optimization of the operation.

Once the differential pressure has been verified, the flow rate is given according to the flow rate graphs in this technote. You may copy the form on page 11 and use it as documentation when verifying the different flow rates in the installation.

4

Measurement of the differential pressure across the valve

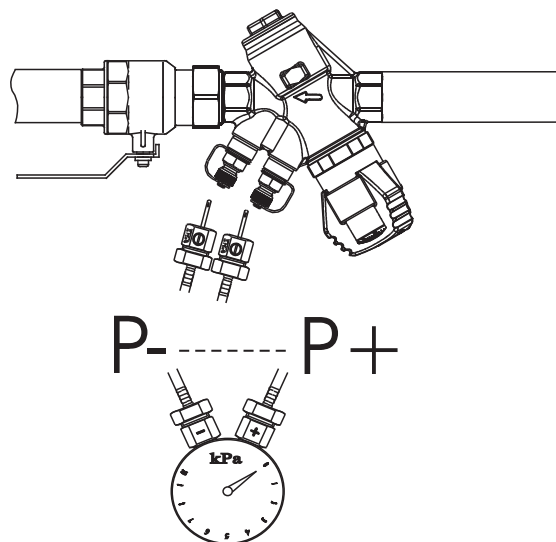

Frese S - dynamic balancing valve

Application sketches

Frese S system in circuit with heating surfaces

The system is easily balanced by adjusting the pump according to the required differential pressure across the critical valve (P+ - P-).

When the differential pressure is available the system will automatically be balanced.

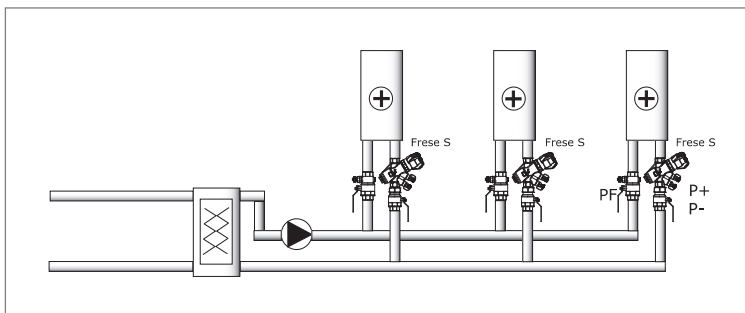

Frese S in installation with mixing loops

Please note:

The balance is controlled by the Frese S valves fitted in each control zone. Major branch balancing valves are eliminated, even if the system may be larger and with far more branches than shown in this simplified diagram.

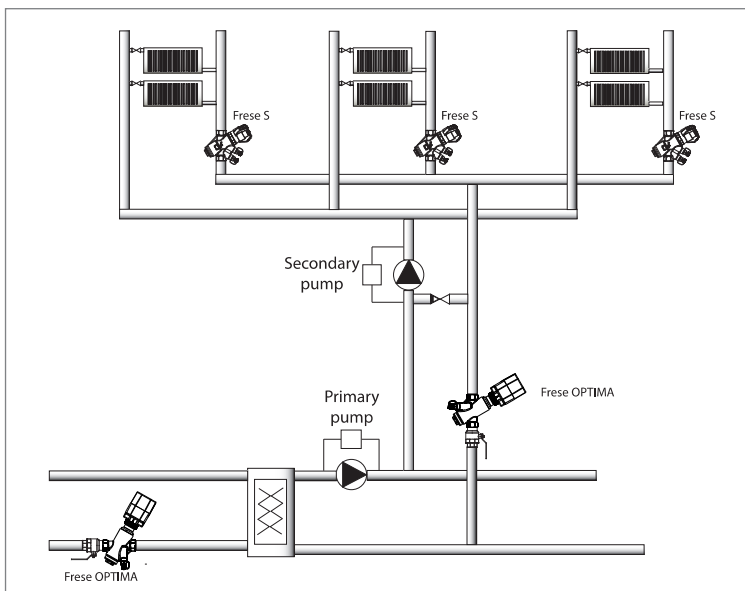

Flow rate example Frese S, DN15

Rated flow 500 l/h - 0,0139 l/s

1. The rated flow is used as the point of reference for the overall rating of dynamic systems. (See the graph)
2. The pre-setting for the valve is found by means of the flow rate graph. Setting = 5.2.
3. To the right in the graph you will see the minimum differential pressure required from the pump by each valve. Requires 18,3 kPa.

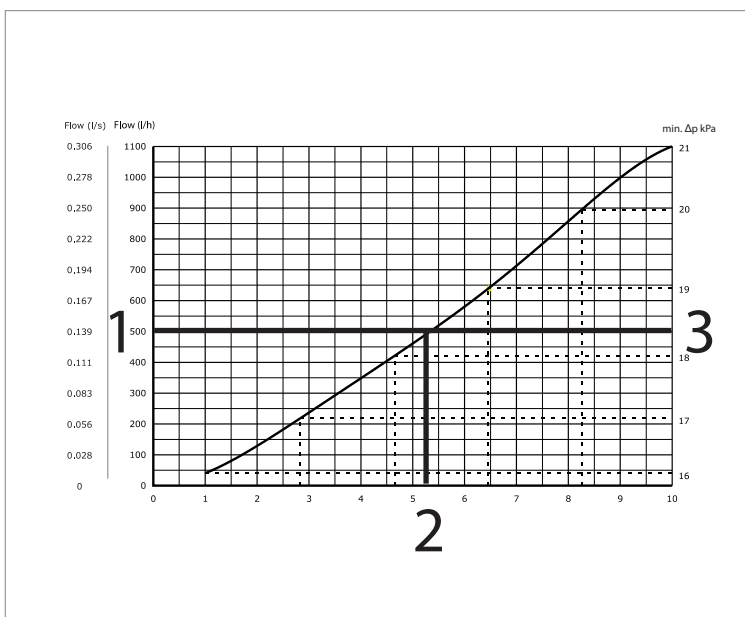

Frese S - dynamic balancing valve

Technical data

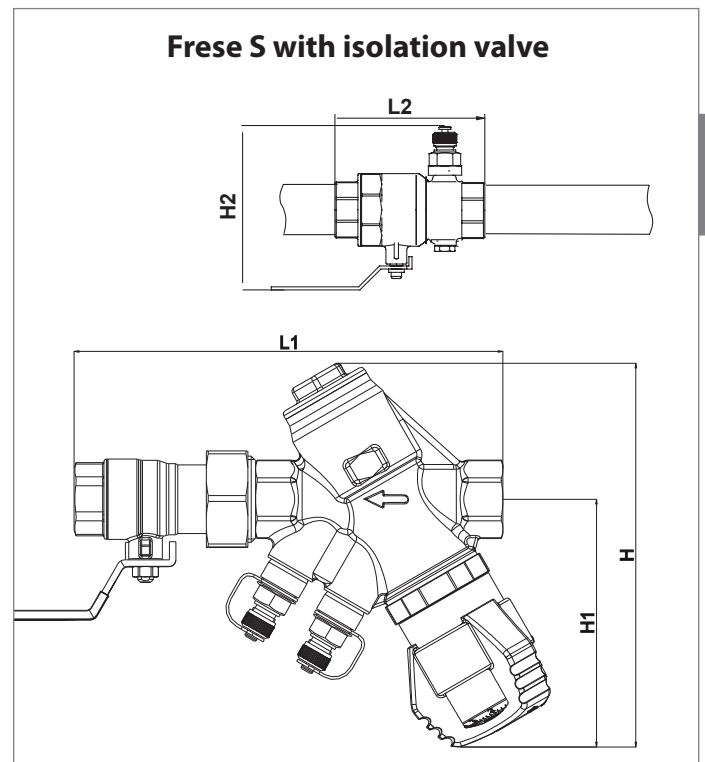
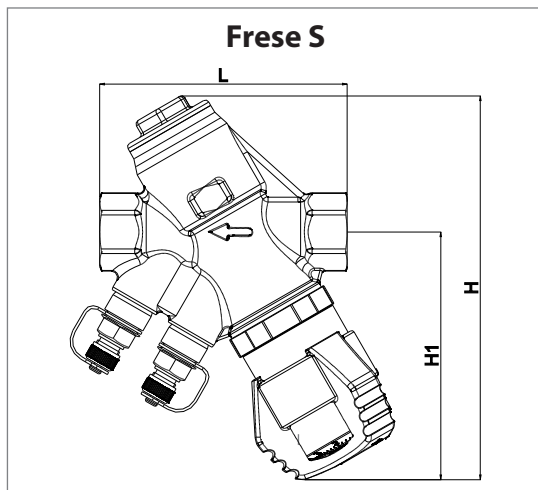

Housing:	DZR, Brass
DP controller:	PPS 40% glass
Flow setting:	PPO
Spring:	Stainless steel
Diaphragm:	HNBR
O-rings:	EPDM
Pressure class:	PN25 (without isolation valve) PN16 (with isolation valve)
Max. differential pressure:	400 kPa (High pressure) 250 kPa (Low pressure)
Temperature range:	-10°C to + 120°C

The pipe system shall be properly ventilated to avoid risk of air pockets. Glycolic mixtures up to 50% are applicable (both ethylene and propylene). Frese A/S can accept no responsibility if another actuator is used instead of the Frese actuator

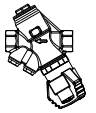

Dimension		DN15	DN20	DN25	DN32	DN40	DN50
Flow rate	HP	0.011 - 0.306	0.018 - 0.512	0.025 - 0.653	0.060 - 1.328	0.049 - 2.067	0.122 - 2.868
	LP	0.007 - 0.223	0.011 - 0.351	0.017 - 0.462			
l/s	HP	40 - 1100	66 - 1850	89 - 2350	217 - 4800	175 - 7450	440 - 10350
	LP	25 - 804	41 - 1265	61 - 1663			
l/h	HP	0.18 - 4.85	0.29 - 8.11	0.39 - 10.35	0.96 - 21.04	0.77 - 32.76	1.94 - 45.46
	LP	0.11 - 3.54	0.18 - 5.57	0.27 - 7.32			
gpm	HP	96	97	103	132	144	155
	LP	167	173	202	235	257	286
Dimension mm	H	148	151	155	188	206	219
	H1	96	98	102	115	119	126
	L	75	82	95	100	108	127
	L1	95	103	111	135	145	164
	L2						
	H2						
KVs		HP 2.4/LP 2.2	HP 3.6/LP 3.3	HP 4.4/LP 4.1	8.8	13.2	16.7

Frese S - dynamic balancing valve

Frese S without Isolation Valve							
		DN15	DN20	DN25	DN32	DN40	DN50
PT Plugs		(HP) 53-2000 (LP) 53-2006	(HP) 53-2001 (LP) 53-2007	(HP) 53-2002 (LP) 53-2008	(HP) 53-2003	(HP) 53-2004	(HP) 53-2005
Plugs		(HP) 53-2010	(HP) 53-2011	(HP) 53-2012	(HP) 53-2013	(HP) 53-2014	(HP) 53-2015
Plug + drain valve		(HP) 53-2030 (LP) 53-2036	(HP) 53-2031 (LP) 53-2037	(HP) 53-2032 (LP) 53-2038	(HP) 53-2033	(HP) 53-2034	(HP) 53-2035

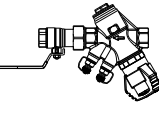
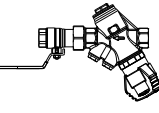
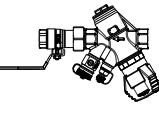
Frese S with Isolation Valve							
		DN15	DN20	DN25	DN32	DN40	DN50
PT Plugs		(HP) 53-2050 (LP) 53-2056	(HP) 53-2051 (LP) 53-2057	(HP) 53-2052 (LP) 53-2058	(HP) 53-2053	(HP) 53-2054	(HP) 53-2055
Plugs		(HP) 53-2060	(HP) 53-2061	(HP) 53-2062	(HP) 53-2063	(HP) 53-2064	(HP) 53-2065
Plug + drain valve		(HP) 53-2080 (LP) 53-2086	(HP) 53-2081 (LP) 53-2087	(HP) 53-2082 (LP) 53-2088	(HP) 53-2083	(HP) 53-2084	(HP) 53-2085

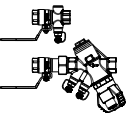
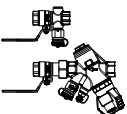
Frese S System							
		DN15	DN20	DN25	DN32	DN40	DN50
PT plugs		(HP) 53-2120 (LP) 53-2126	(HP) 53-2121 (LP) 53-2127	(HP) 53-2122 (LP) 53-2128	(HP) 53-2123	(HP) 53-2124	(HP) 53-2125
Plug + 2 drain valves		(HP) 53-2130 (LP) 53-2136	(HP) 53-2131 (LP) 53-2137	(HP) 53-2132 (LP) 53-2138	(HP) 53-2133	(HP) 53-2134	(HP) 53-2135

Text for technical Specifications

The valve should be a automatic balancing valve with the option of setting the flow without interference of operation.

The valve should include P/T plugs for the verification of differential pressure.

The valve should only be adjustable by means of a lockable handle.

Frese S - dynamic balancing valve

Flow rate graph Frese S, DN15 High Pressure

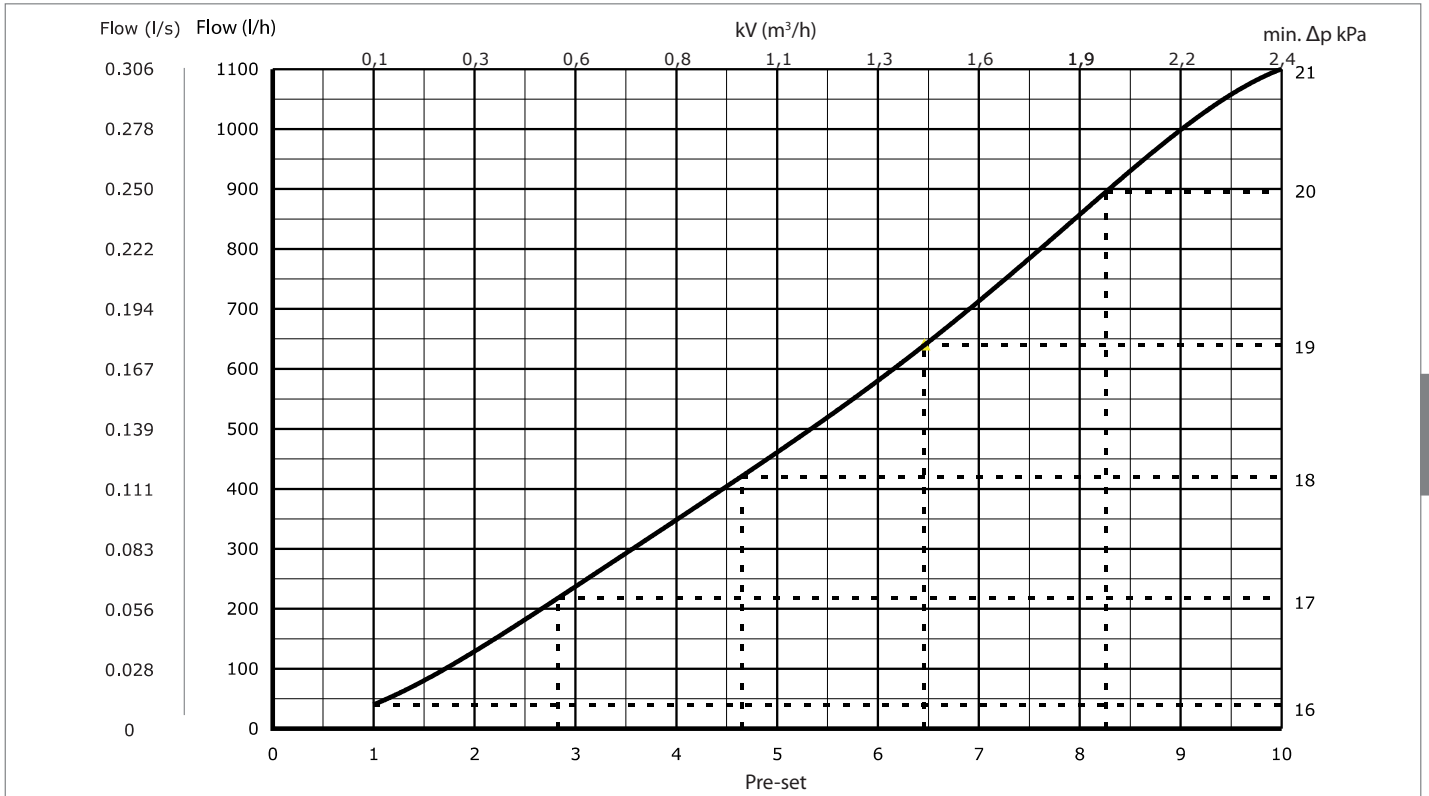

Flow rate graph Frese S, DN20 High Pressure

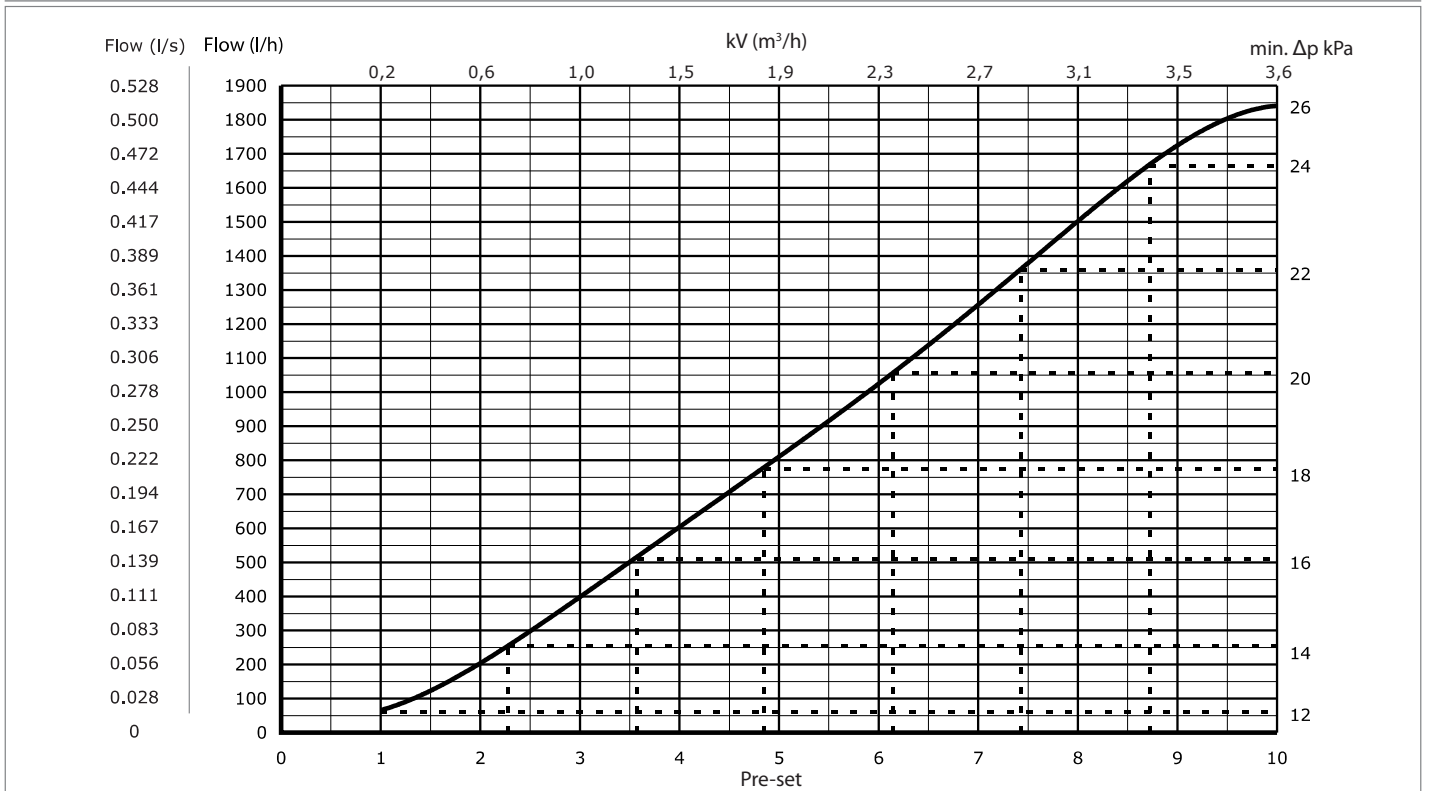

Frese S - dynamic balancing valve

Flow rate graph Frese S, DN25 High Pressure

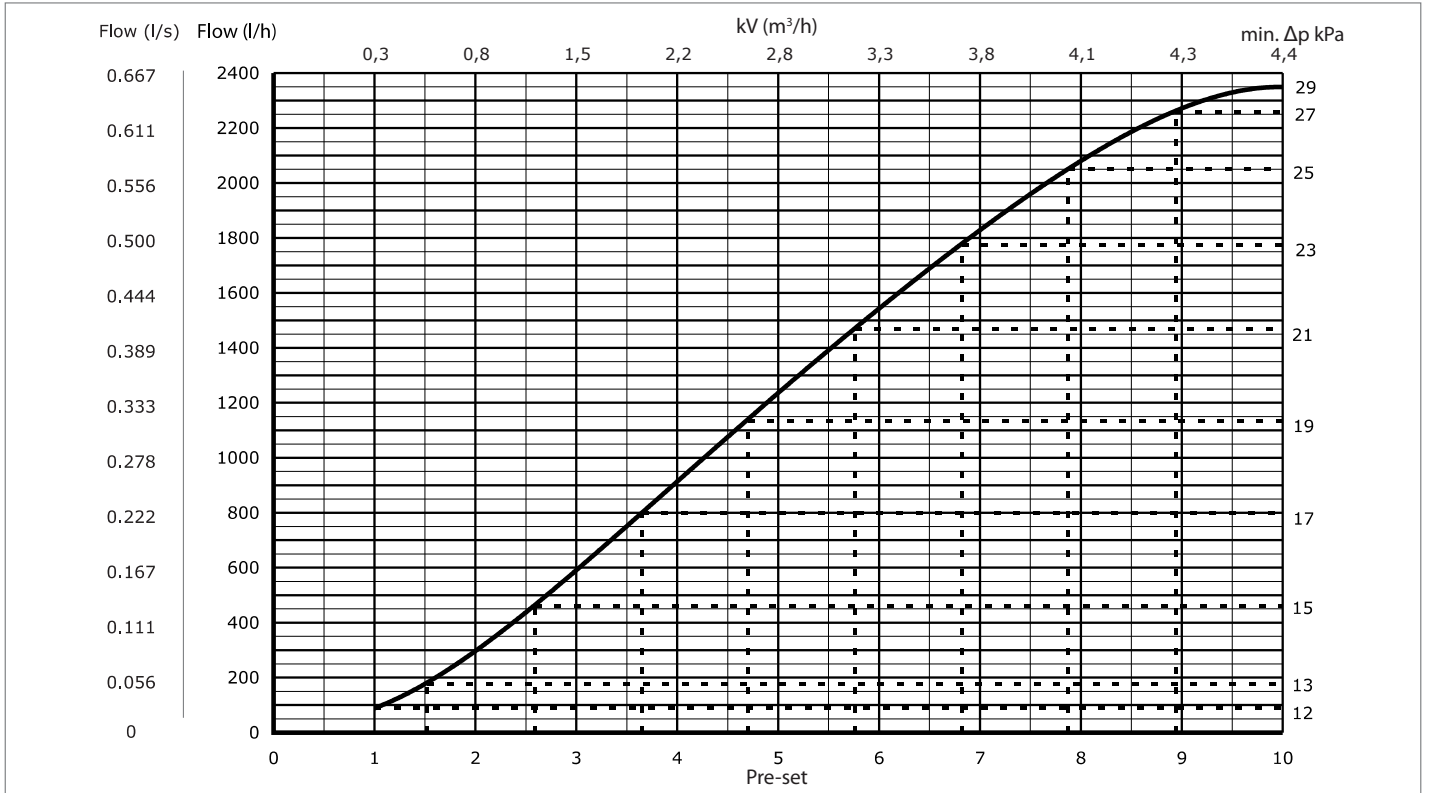

Flow rate graph Frese S, DN32 High Pressure

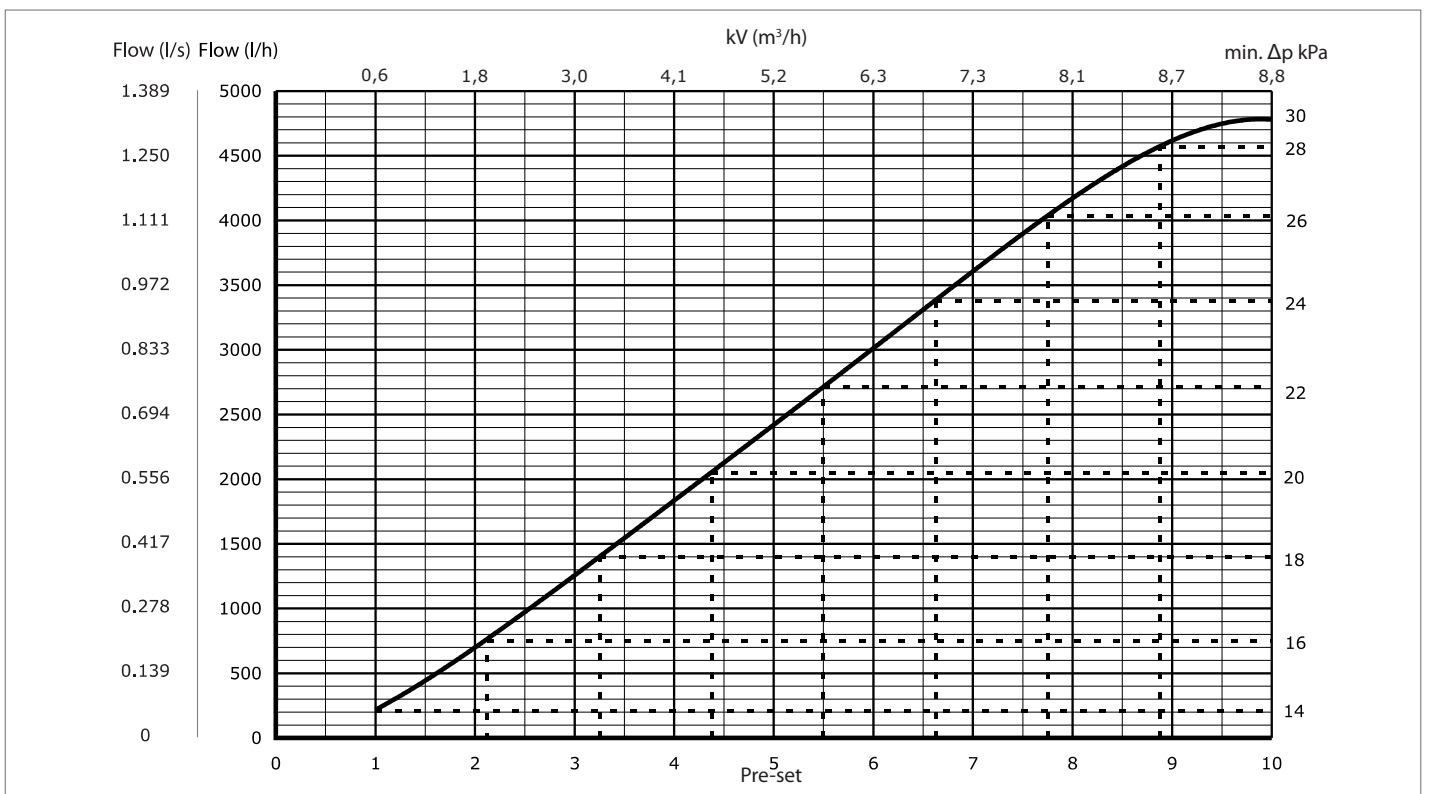

Frese S - dynamic balancing valve

Flow rate graph Frese S, DN40 High Pressure

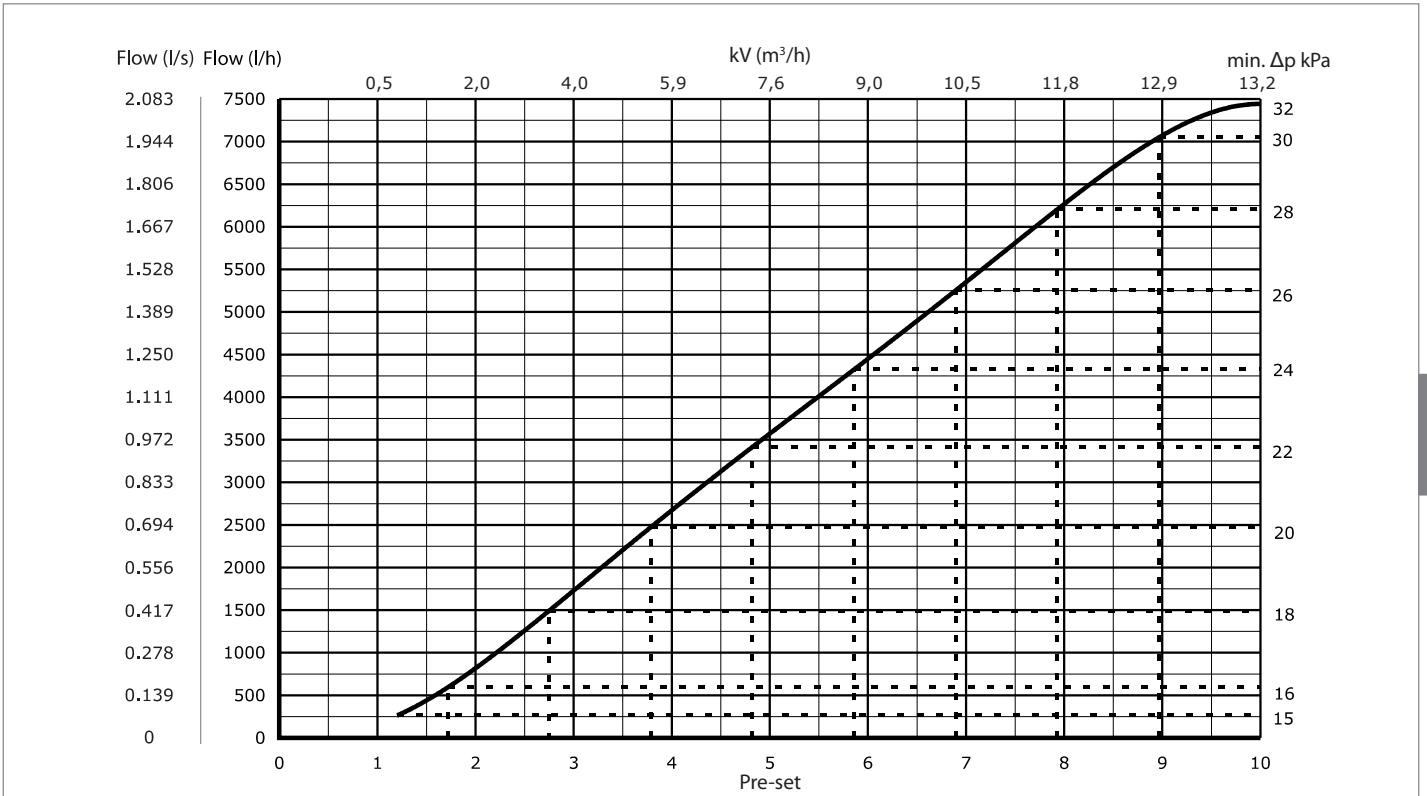

Flow rate graph Frese S, DN50 High Pressure

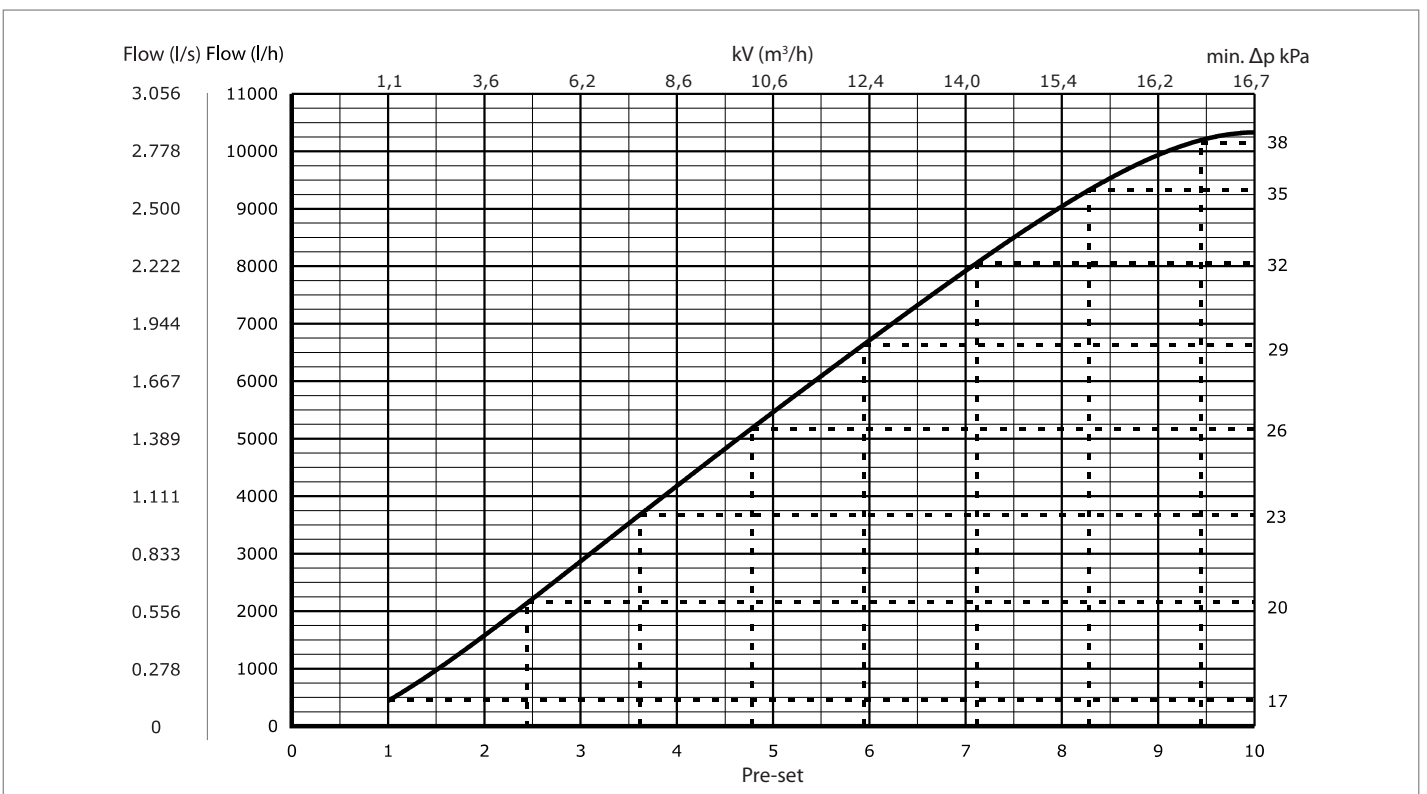

Frese S - dynamic balancing valve

Flow rate graph Frese S DN15 Low Pressure

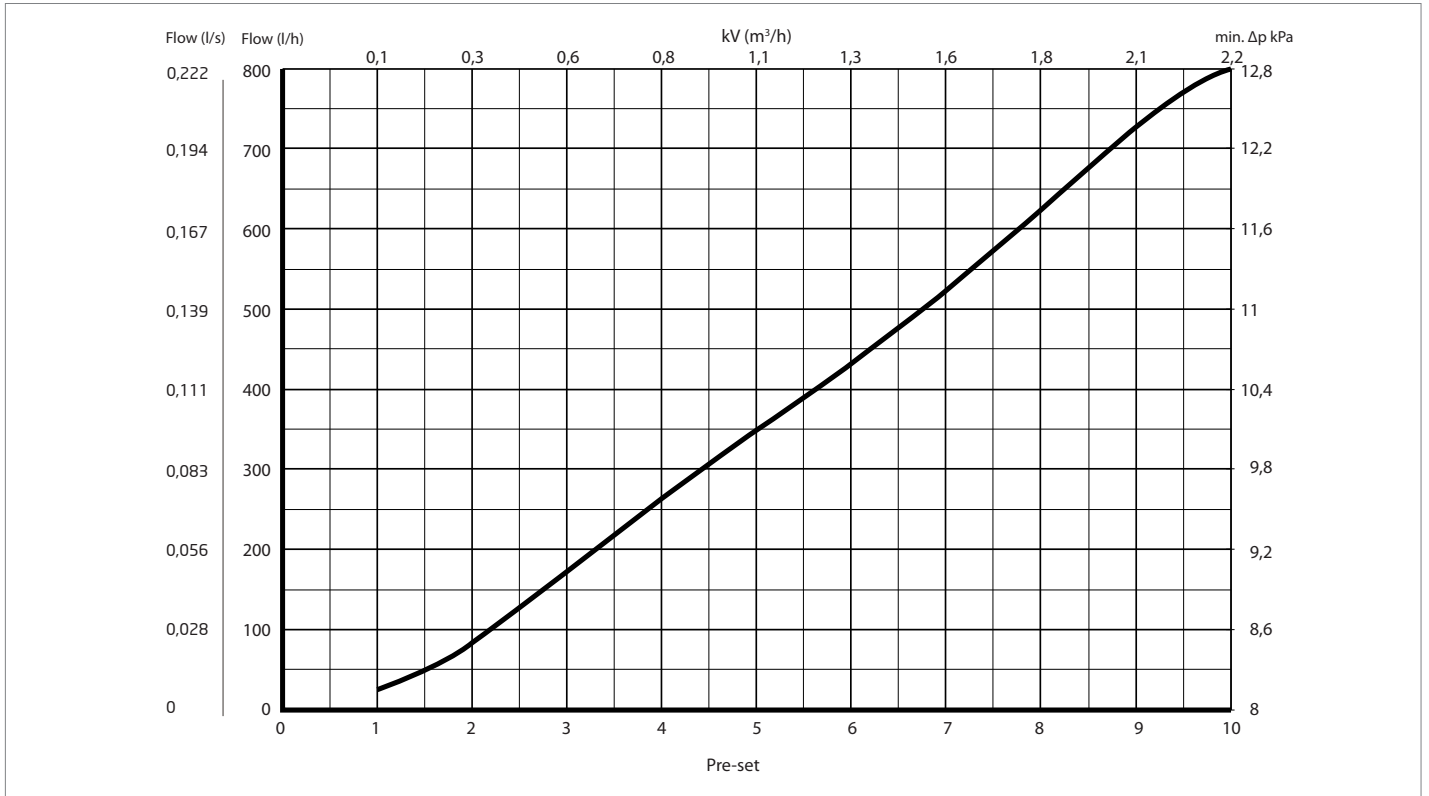

Flow rate graph Frese S DN20 Low Pressure

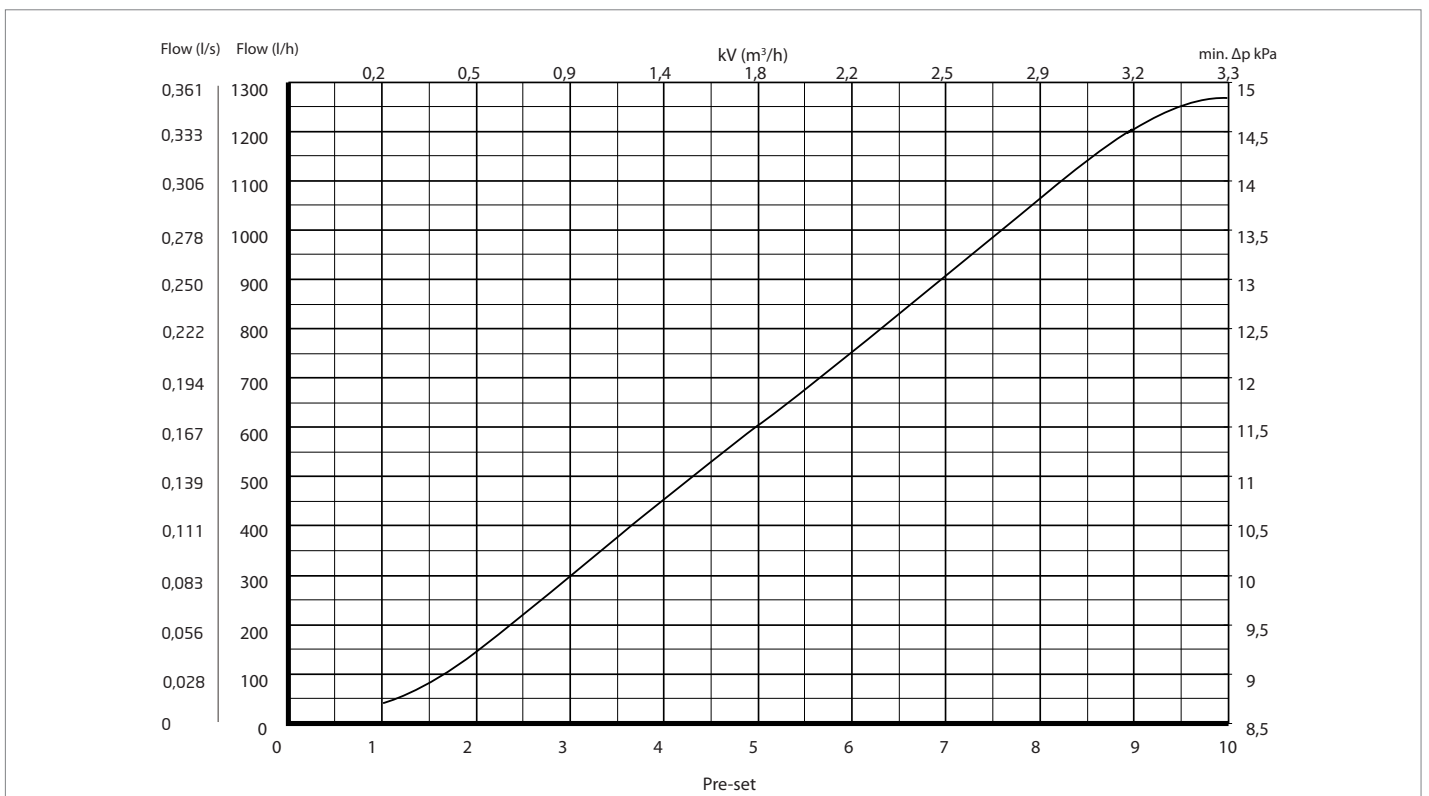

Frese S - dynamic balancing valve

Flow rate graph Frese S DN25 Low Pressure

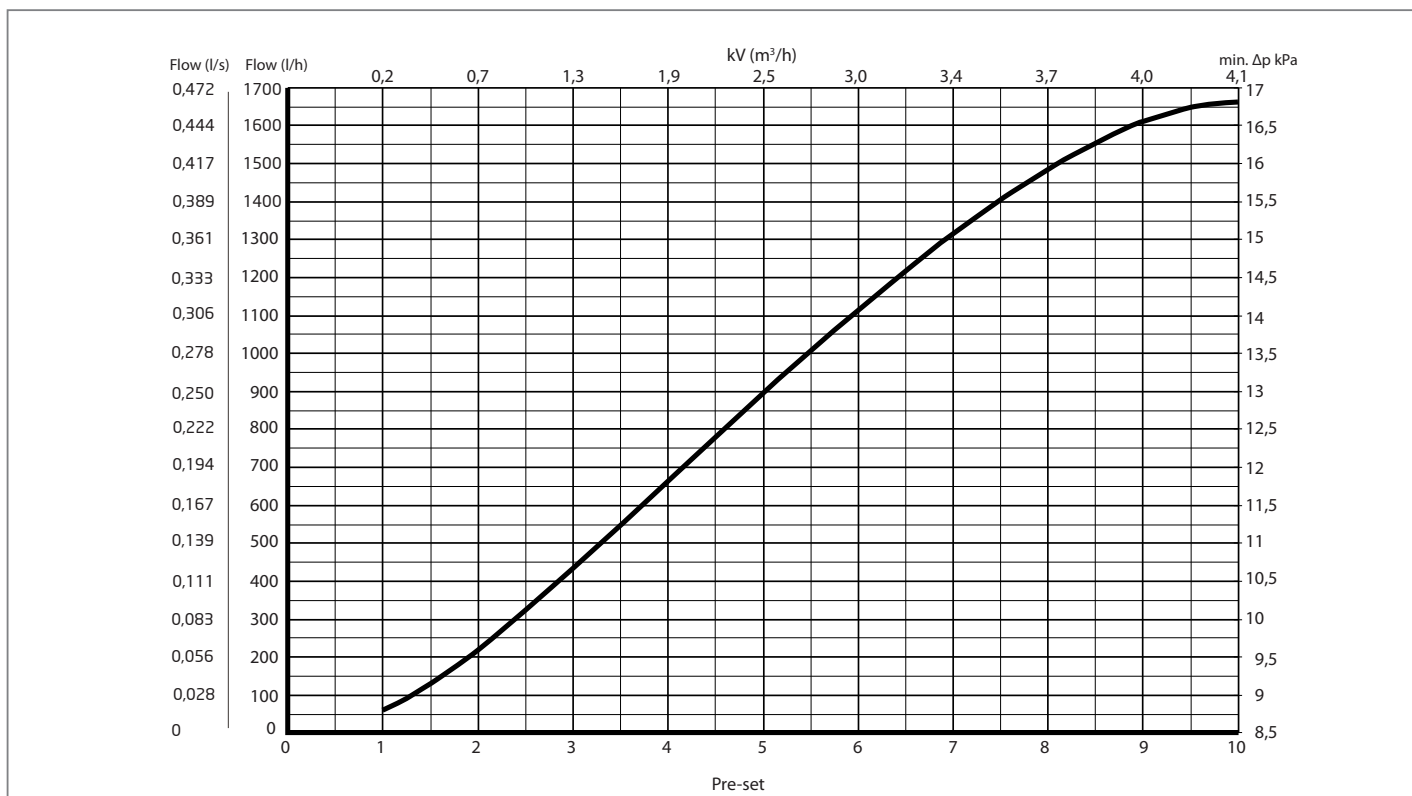

Frese S DN15 LP

Frese S DN20 LP

Frese S DN25 LP

Pre-setting	Flow		
	l/h	l/s	gpm
1,00	25	0,007	0,11
1,50	48	0,013	0,21
2,00	84	0,023	0,37
2,50	127	0,035	0,56
3,00	172	0,048	0,76
3,50	218	0,061	0,96
4,00	263	0,073	1,16
4,50	306	0,085	1,35
5,00	348	0,097	1,53
5,50	390	0,108	1,72
6,00	433	0,120	1,90
6,50	477	0,132	2,10
7,00	524	0,145	2,31
7,50	573	0,159	2,52
8,00	625	0,174	2,75
8,50	678	0,188	2,98
9,00	728	0,202	3,20
9,50	772	0,214	3,40
10,00	804	0,223	3,54

Pre-setting	Flow		
	l/h	l/s	gpm
1,00	41	0,011	0,18
1,50	82	0,023	0,36
2,00	145	0,040	0,64
2,50	218	0,061	0,96
3,00	297	0,083	1,31
3,50	377	0,105	1,66
4,00	455	0,126	2,00
4,50	531	0,147	2,34
5,00	605	0,168	2,66
5,50	678	0,188	2,99
6,00	752	0,209	3,31
6,50	828	0,230	3,65
7,00	906	0,252	3,99
7,50	985	0,274	4,34
8,00	1064	0,296	4,68
8,50	1139	0,316	5,01
9,00	1204	0,334	5,30
9,50	1249	0,347	5,50
10,00	1265	0,351	5,57

Pre-setting	Flow		
	l/h	l/s	gpm
1,00	61	0,017	0,27
1,50	131	0,036	0,58
2,00	220	0,061	0,97
2,50	322	0,089	1,42
3,00	432	0,120	1,90
3,50	547	0,152	2,41
4,00	664	0,184	2,92
4,50	780	0,217	3,43
5,00	895	0,249	3,94
5,50	1007	0,280	4,43
6,00	1114	0,310	4,91
6,50	1218	0,338	5,36
7,00	1315	0,365	5,79
7,50	1405	0,390	6,19
8,00	1486	0,413	6,54
8,50	1557	0,432	6,85
9,00	1612	0,448	7,10
9,50	1650	0,458	7,26
10,00	1663	0,462	7,32

Frese S - dynamic balancing valve

Setting and Flow

Frese S DN15 HP				Frese S DN20 HP			Frese S DN25 HP		
Pre-setting	Flow			l/h	Flow		l/h	Flow	
	l/h	l/s	gpm		l/s	gpm		l/s	gpm
1,00	40	0,011	0,18	66	0,018	0,29	89	0,025	0,39
1,50	80	0,022	0,35	123	0,034	0,54	177	0,049	0,78
2,00	129	0,036	0,57	204	0,057	0,90	297	0,082	1,31
2,50	182	0,051	0,80	298	0,083	1,31	438	0,122	1,93
3,00	237	0,066	1,04	398	0,111	1,75	591	0,164	2,60
3,50	293	0,081	1,29	501	0,139	2,21	751	0,209	3,31
4,00	348	0,097	1,53	604	0,168	2,66	914	0,254	4,02
4,50	404	0,112	1,78	707	0,196	3,11	1076	0,299	4,74
5,00	461	0,128	2,03	810	0,225	3,57	1236	0,343	5,44
5,50	519	0,144	2,29	916	0,254	4,03	1391	0,387	6,13
6,00	581	0,161	2,56	1025	0,285	4,51	1543	0,429	6,79
6,50	645	0,179	2,84	1138	0,316	5,01	1689	0,469	7,43
7,00	713	0,198	3,14	1257	0,349	5,53	1828	0,508	8,05
7,50	784	0,218	3,45	1379	0,383	6,07	1960	0,544	8,63
8,00	858	0,238	3,78	1502	0,417	6,61	2081	0,578	9,16
8,50	931	0,258	4,10	1620	0,450	7,13	2187	0,607	9,63
9,00	999	0,278	4,40	1725	0,479	7,59	2273	0,631	10,00
9,50	1059	0,294	4,66	1804	0,501	7,94	2331	0,647	10,26
10,00	1100	0,306	4,85	1850	0,512	8,11	2350	0,653	10,35

Frese S DN32 HP				Frese S DN40 HP			Frese S DN50 HP		
Pre-setting	Flow			l/h	Flow		l/h	Flow	
	l/h	l/s	gpm		l/s	gpm		l/s	gpm
1,00	217	0,060	0,96	175	0,049	0,77	440	0,122	1,94
1,50	443	0,123	1,95	439	0,122	1,93	976	0,271	4,29
2,00	699	0,194	3,08	818	0,227	3,60	1576	0,438	6,94
2,50	973	0,270	4,28	1260	0,350	5,55	2214	0,615	9,75
3,00	1257	0,349	5,53	1730	0,480	7,61	2868	0,797	12,62
3,50	1545	0,429	6,80	2204	0,612	9,70	3525	0,979	15,52
4,00	1836	0,510	8,08	2672	0,742	11,76	4179	1,161	18,40
4,50	2127	0,591	9,36	3127	0,868	13,76	4824	1,340	21,24
5,00	2420	0,672	10,65	3571	0,992	15,72	5461	1,517	24,04
5,50	2714	0,754	11,95	4009	1,114	17,65	6089	1,691	26,80
6,00	3012	0,837	13,26	4449	1,236	19,58	6709	1,864	29,54
6,50	3310	0,919	14,57	4895	1,360	21,55	7321	2,034	32,23
7,00	3607	1,002	15,88	5350	1,486	23,55	7919	2,200	34,86
7,50	3897	1,083	17,16	5811	1,614	25,58	8497	2,360	37,41
8,00	4172	1,159	18,36	6267	1,741	27,59	9041	2,511	39,80
8,50	4418	1,227	19,45	6698	1,861	29,49	9530	2,647	41,95
9,00	4618	1,283	20,33	7072	1,964	31,13	9934	2,760	43,73
9,50	4749	1,319	20,90	7341	2,039	32,32	10216	2,838	44,97
10,00	4800	1,328	21,04	7450	2,067	32,76	10350	2,868	45,46

Frese S - dynamic balancing valve

Documentation formular

Valve ID (own choice)	Valve type	Dimension	Pre-setting	Verified Δp [kPa]	Min. Δp <small>(see flow rate graph)</small> [kPa]	Flow

4

Pump type	Regulation mode	Set point
-----------	-----------------	-----------

Installation	
Signature	Date

Frese A/S assumes no responsibility for errors, if any, in catalogues, brochures, and other printed matter. Frese A/S reserves the right to modify its products without prior notice, including already ordered products, if this does not alter existing specifications. All registered trademarks in this material are the property of Frese A/S. All rights reserved.

Frese A/S
 Sorøvej 8
 DK- 4200 Slagelse
 Tel: +45 58 56 00 00
 Fax: +45 58 56 00 91
 info@frese.dk