

Frese PV - adjustable differential pressure control valve

Application

Frese PV can be installed in domestic and commercial heating and cooling systems.

The valve is a dynamic, adjustable differential pressure control valve (DPCV) that ensures the differential pressure across the load or circuit is constant.

The valve ensures good modulating control and reduces the risk of noise from thermostatic radiator valves and 2-port control valves.

Frese PV can be installed in conjunction with Frese S (adjustable flow limiter) to provide 100% control of the flow and differential pressure regardless of pressure fluctuations in the system. See PVS Technote.

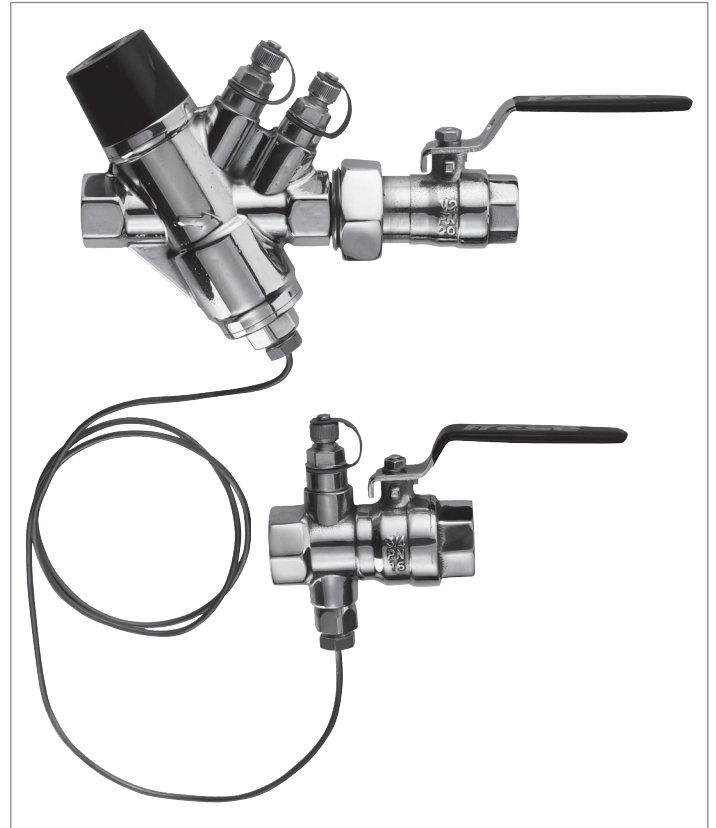

Benefits

- The valve offers three in-built functions: adjustable differential pressure control, isolation and P/T plugs for pressure verification
- Frese PV eliminates noise problems caused by over pressure
- Differential pressure can be set and adjusted on site
- Tamper-proof presetting device on top of the valve, meaning there is no need for the valve sealing after presetting
- Presetting is simple using the graphs shown on pages 9-13

Features

- Maximum differential pressure: 400 kPa
- Removable ΔP cartridge allows forward as well as back-flushing
- Size range: DN15 to DN50
- Maximum flow: 15m³/h
- Built-in P/T plugs for ΔP verification

Frese PV

- adjustable differential pressure control valve

Setting the valve

The valve is easily set by means of a 4mm hexagonal key. The flow rate of the valve can be determined from the flow rate graphs for the valve dimension in question. See the flow rate graphs of the valve on pages 9 and 13 for further information about the Pre-setting.

To set the valve to the desired downstream differential pressure, the valve should be set at the minimum position and then adjusted in accordance with the presetting graphs.

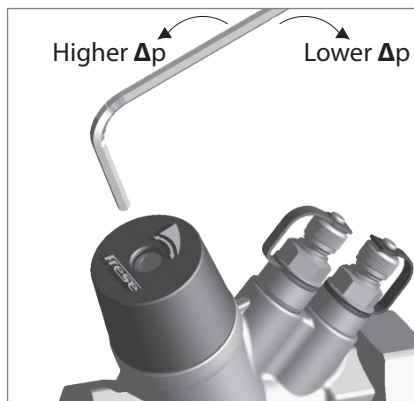

Design

Frese PV consists of a differential pressure regulation unit, isolating ball valve, P/T-plugs and partner valve which is installed in the flow.

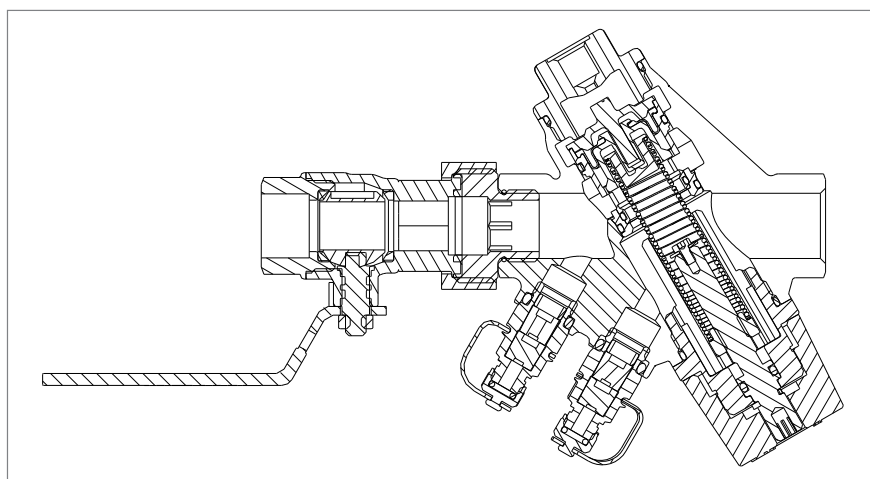

Frese PV system fem./fem. with union and isolation ball valve

Simplified outline Frese PV

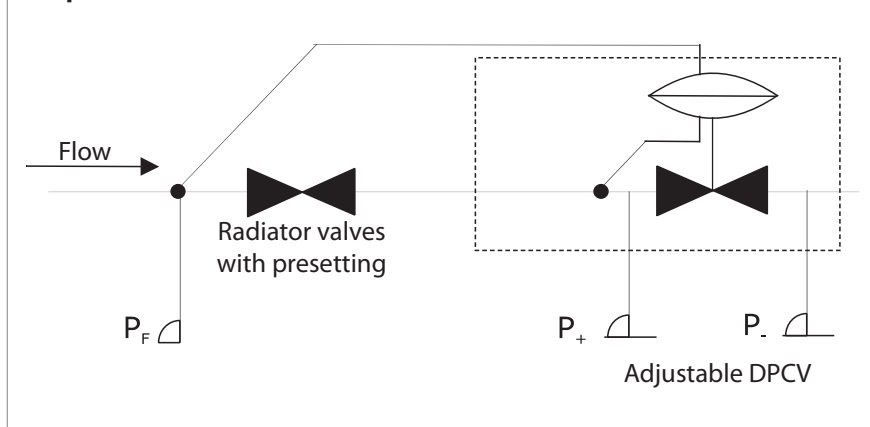

Frese PV - adjustable differential pressure control valve

Technical data

Housing:	DZR, Brass
DP controller:	PPS 40% glass
Flow setting:	PPO
Spring:	Stainless steel
Diaphragm:	HNBR
O-rings:	EPDM
Pressure class:	PN16
Max. differential pressure:	400 kPa
Temperature range:	-10°C to + 120°C
Capillary tube:	Ø3, L = 1000mm

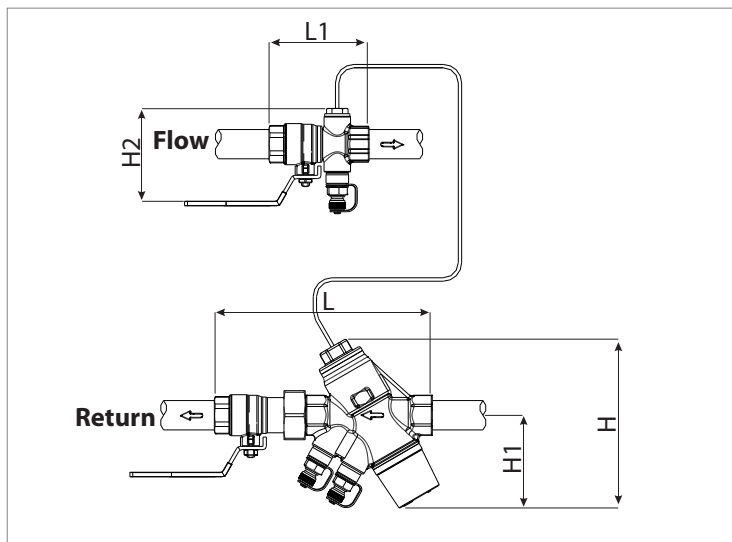

Frese PV System - Valve combination, capillary tube, isolation ball valve at the supply- and return line.

Type		Frese PV								
Application		Two pipe systems								
Dimension		DN15		DN20		DN25		DN32	DN40	DN50
Control range	[kPa]	5-30	20-60	5-30	20-60	5-30	20-60	20-80	20-80	20-80
Flow rate	[l/s]	0,014-0,167	0,028-0,333	0,028-0,278	0,042-0,556	0,167-0,694	0,194-1,167	0,278-1,389	0,833-2,222	1,389-4,167
	[l/h]	50-600	100-1200	100-1000	150-2000	600-2500	700-4200	1000-5000	3000-8000	5000-15000
	gpm	0,22-2,65	0,44-5,29	0,44-4,41	0,66-8,82	2,65-11,02	3,09-18,52	4,41-22,05	13,23-35,27	22,05-66,14
Dimension mm	L	167		173		232		235	257	286
	H	127		130		166		166	184	196
	H1	70		73		91		91	97	106
	L1	75		82		95		100	108	127
	H2	95		103		111		135	145	164
Accuracy		+/- 7%		+/- 7%		+/- 7%		+/- 7%	+/- 7%	+/- 7%
	Kvs	3,6		4		9,5		11,4	16,4	17,9

Frese PV - adjustable differential pressure control valve

Example

Outline of the heating system in one of the sections. 5 staircases with 4 flats each. Pump and tank farther away than indicated in the example.

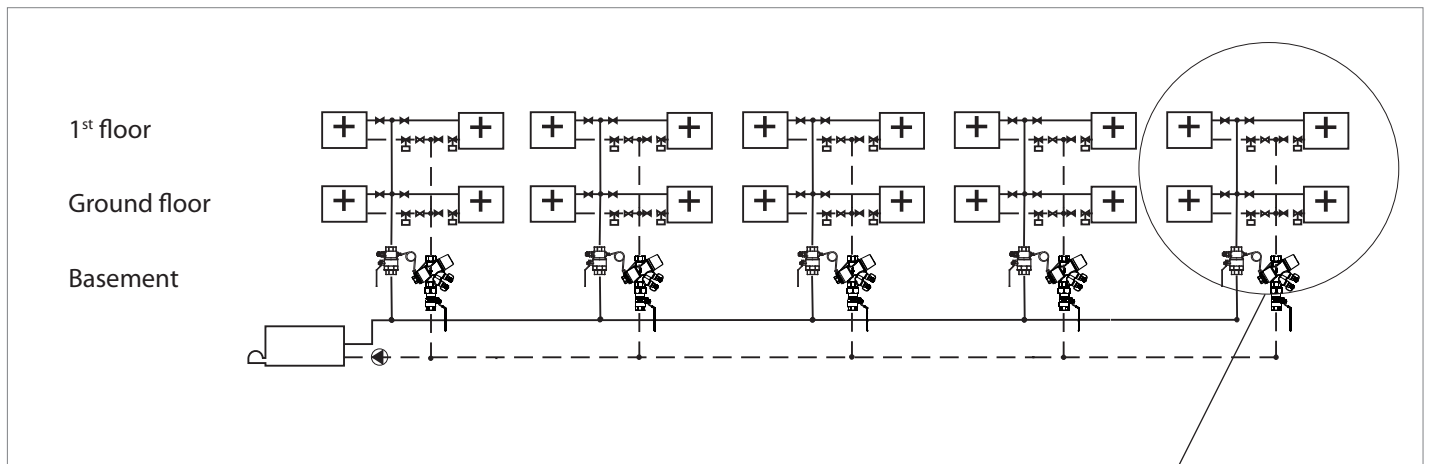

Evidently the pressure will be higher in the supply pipes near the pump than e.g. in the critical pipe.

In this case the purpose of Frese PV is to maintain pressure of approx. 12 kPa across the supply and the return line.

Specifying the characteristics of the building, the calorific requirement was rated at 125 l/h per flat.

Motor valves were chosen for the control of the flow. The Kvs-value of these should be as close to 0.36 m³/h as possible. (125 l/h and 12 kPa),
 $Q = K_v * \sqrt{\Delta p}$.

As already mentioned a differential pressure of 12 kPa should be maintained at a flow of 4 x 125 = 500 l/h.

From the scheme on page 3, which shows the technical data of Frese PV, a Frese PV DN15 will be suitable for the purpose.

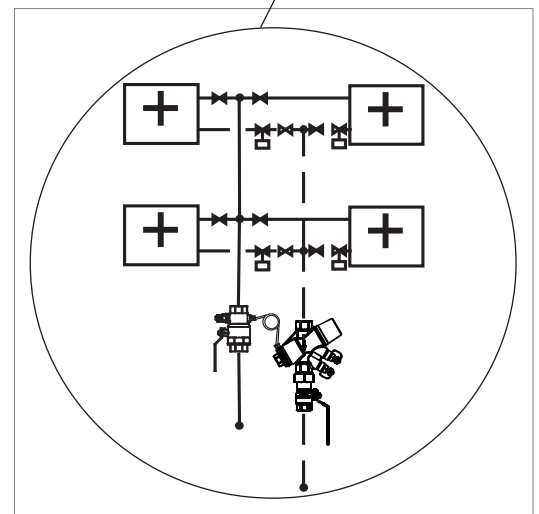

Index Circuit

Frese PV - adjustable differential pressure control valve

Example

The adjustment setting of the Frese PV⁺ valve is specified on the basis of the graph. In order to make reading easier the graphs indicating the pressure in the circuit are arranged at intervals of 5 kPa. Still, the graphs can be offset according to the specified pressure of 12 kPa in our circuit.

In the given example we want to maintain 12 kPa in the circuit at a flow rate of 500 l/h. From the intersection of the 12 kPa graph and the horizontal line indicating 500 l/h a line perpendicular to the x-axis is made to read the pre-set value. Now you will see that the valve is to be pre-set by app. 7 turns on the scale.

The minimum pressure drop required will be 1.9 kPa across the valve.

Consequently, the total pressure drop required when rating the pump will be:

$$\Delta P_p = \Delta P_s + \Delta P_v = 12 + 1.9 = 13.9 \text{ kPa.}$$

Now the pump can be throttled to operate at its optimum, by measuring from P_F to P- (ΔP_{pump}).

To verify that the calculated secondary pressure drop across the circuit is correct, measurements can be carried out from P_F to P+, and should read 12 kPa as dimensioned.

Measurement of the differential pressure across the valve

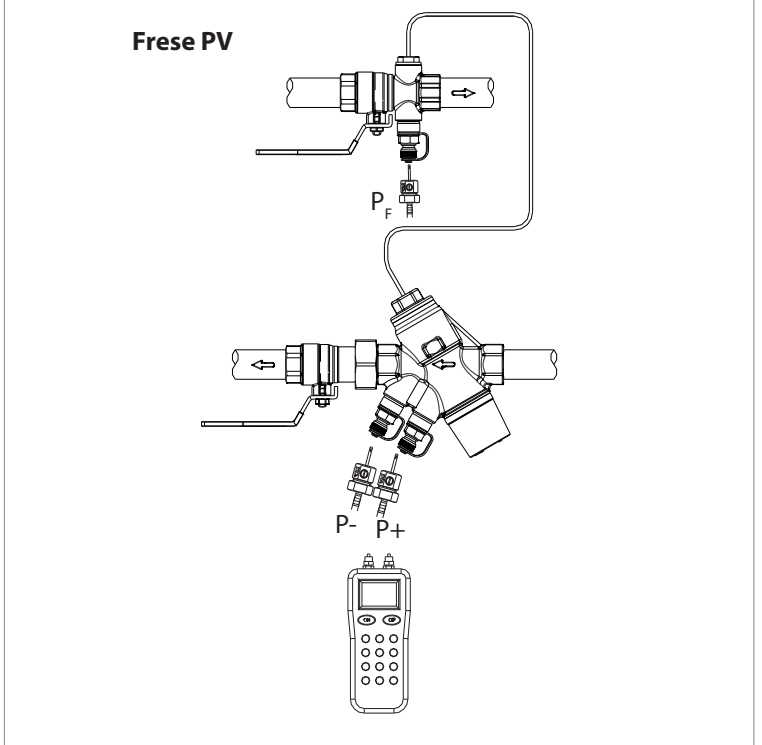

Flow rate graph - Frese PV DN15

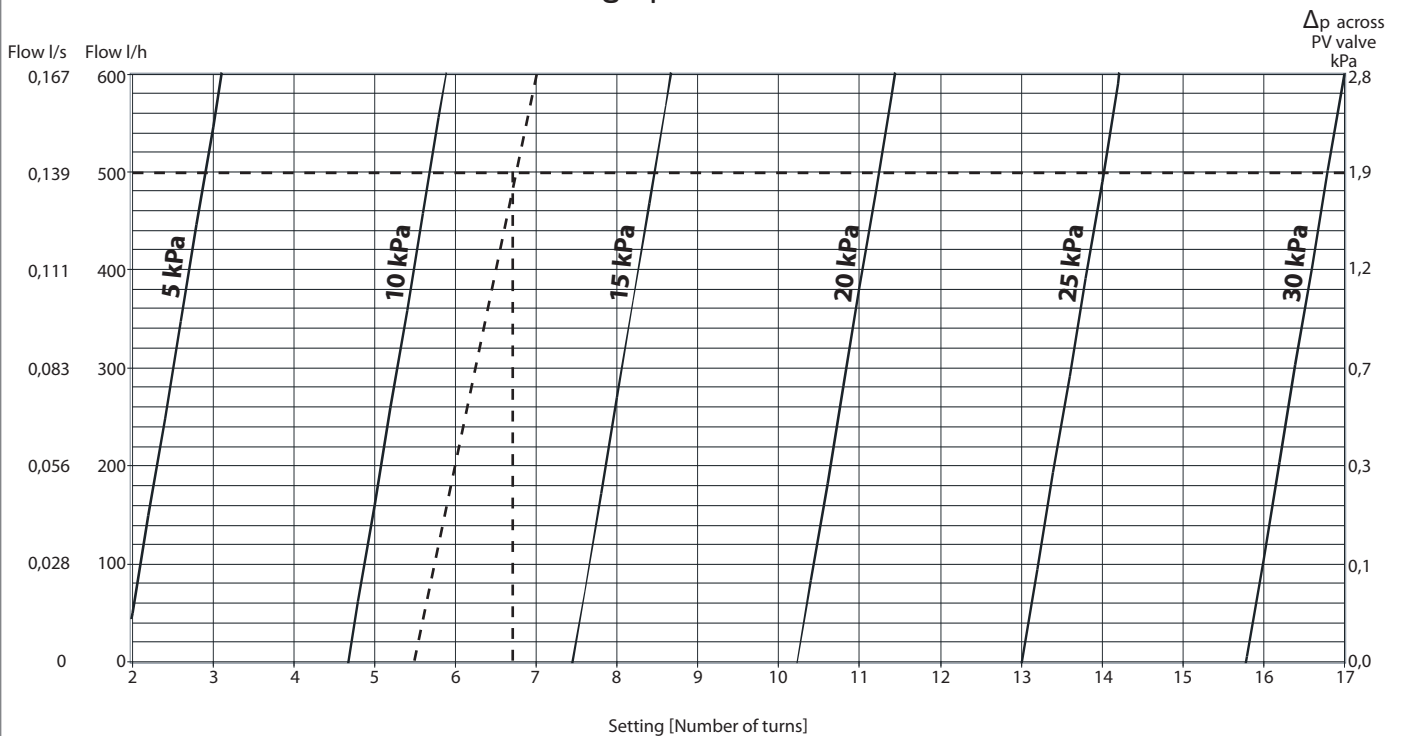

Frese PV - adjustable differential pressure control valve

Example

Please note:

As the flow is reduced in the circuit in question the pressure increases in reverse ratio to the flow, which is due to the P-band of the adjustment spring. The valve still compensates for this. However, the pressure will nowhere in the circuit be as high as the pump pressure that would have been available if Frese PV had not been installed.

In this example the pressure increases to approx. 14 kPa as the graph is offset parallel to the course of flow. Furthermore, you can always read from the graph what the pressure in the circuit will be like at any flow rate below the rated 500 l/h.

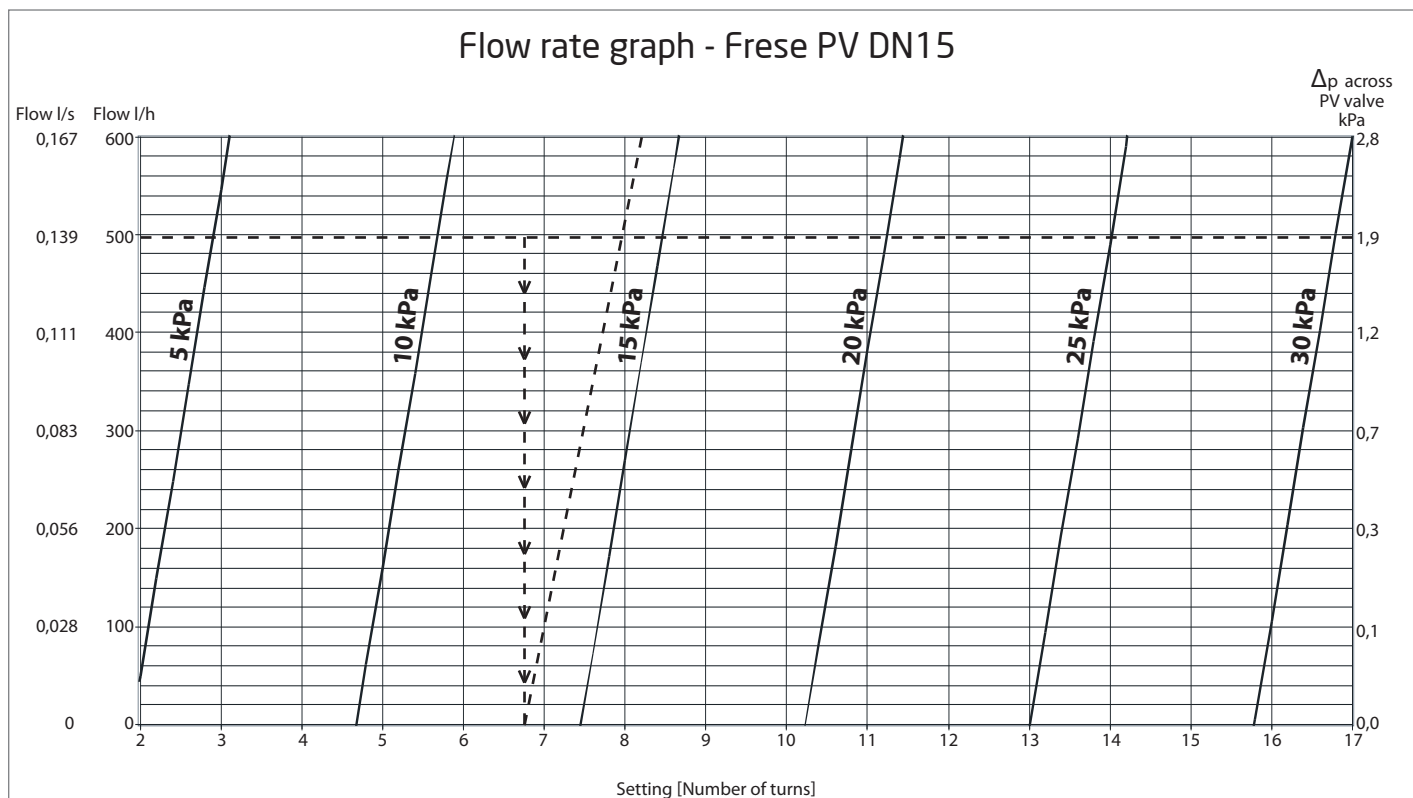
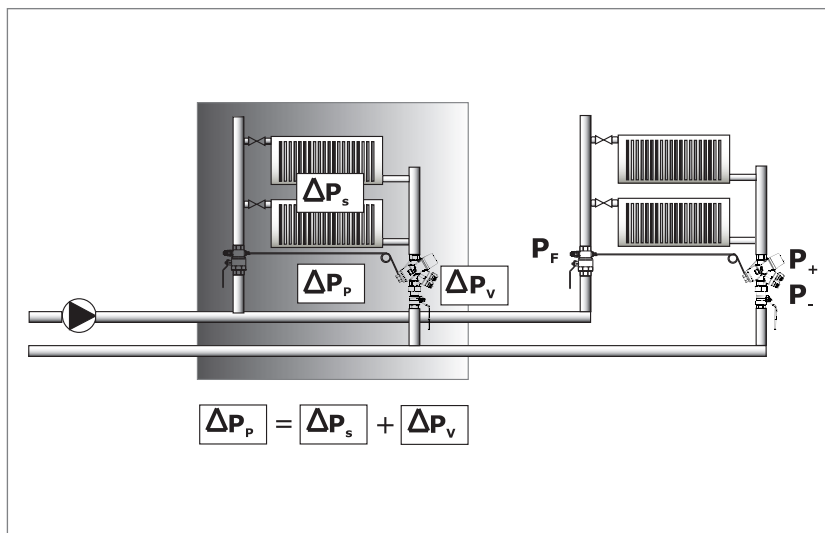





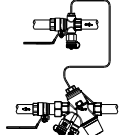
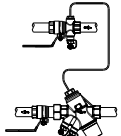

Frese PV - adjustable differential pressure control valve

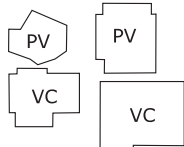
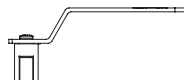
Product programme PV

	Dimension	DN15	DN20	DN25	DN32	DN40	DN50
With isolation ball-valves, 2 drain valves, plug, capillary tube and union connection.		53-3000 (5-30 kPa)	53-3001 (5-30 kPa)	53-3002 (5-30 kPa)	53-3003 (20-80 kPa)	53-3004 (20-80 kPa)	53-3005 (20-80 kPa)
With isolation ball-valves, 1" P/T plugs, capillary tube and union connection.		53-3010 (5-30 kPa)	53-3011 (5-30 kPa)	53-3012 (5-30 kPa)	53-3013 (20-80 kPa)	53-3014 (20-80 kPa)	53-3015 (20-80 kPa)
		53-3016 (20-60 kPa)	53-3017 (20-60 kPa)	53-3018 (20-60 kPa)			

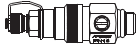
Accessories

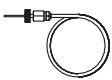
		Frese no.	Dim./DN
Insulation jackets		38-0845	PV 15/20/25
		38-0854	PV 32/40/50
		38-0856	VC 15/20/25
		38-0848	VC 32/40/50
Spindle extension		46-1072	15/20
		46-1073	25
		46-1074	32/40
		46-1075	50
Frese capillary tube 3mm x 1000 mm		48-0004	
Drain valve		48-0009	1/4" x 1/2
Plug		09-0548	
Combi drain valve		48-0015	1/4" x 1/2
P/T plugs	Blue strip	48-0012	1/4" x 1"
		48-0013	1/4" x 2"
		48-0014	1/4" x 4"
	Red strip	48-0018	1/4" x 1"
		48-0019	1/4" x 2"
		48-0021	1/4" x 4"
Frese manometer 2023P Digital differential pressure manometer hose kit and needles.		48-0022	
Hose kit incl. needles		48-0016	

Frese PV

- adjustable differential pressure control valve

Frese PV DN15, 5-30 kPa

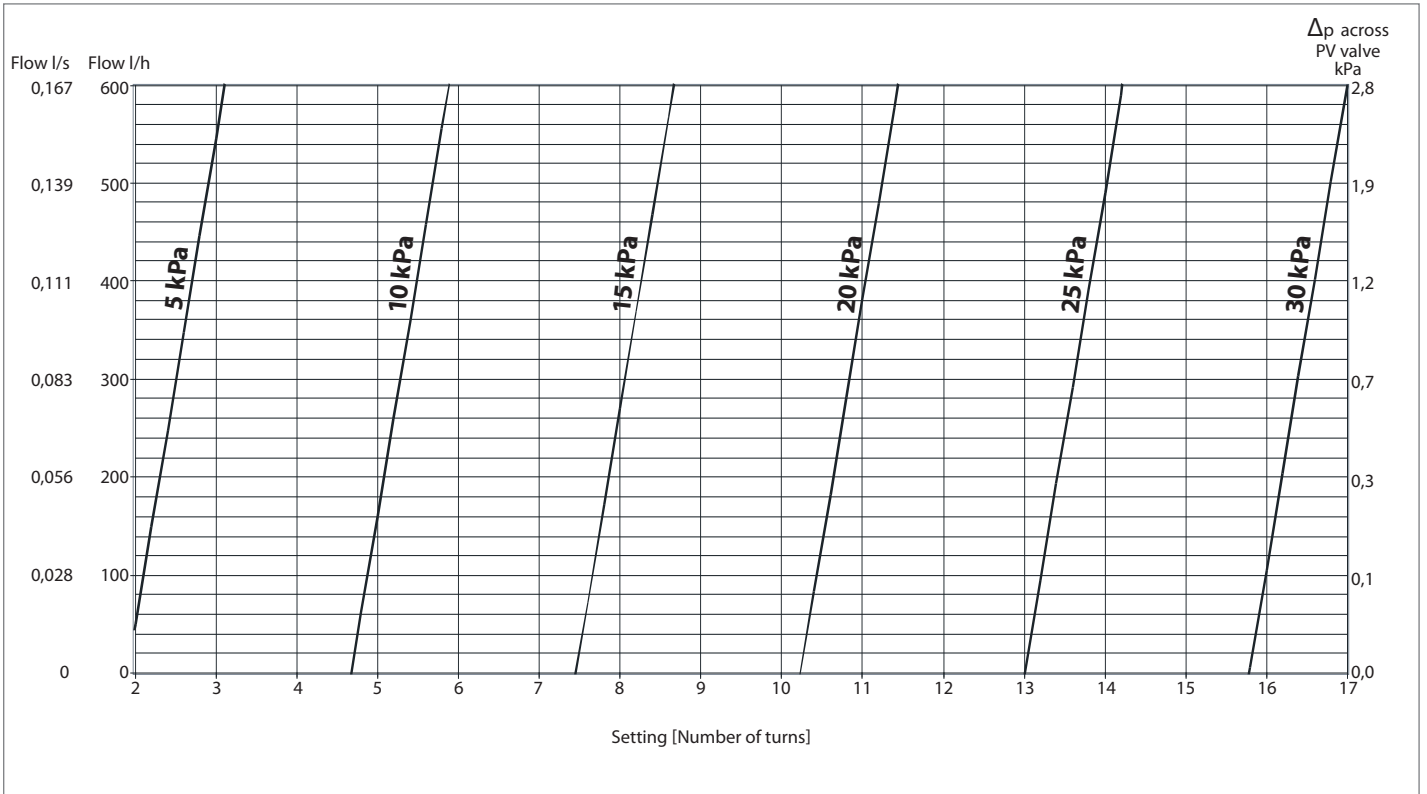

Frese PV DN15, 20-60 kPa

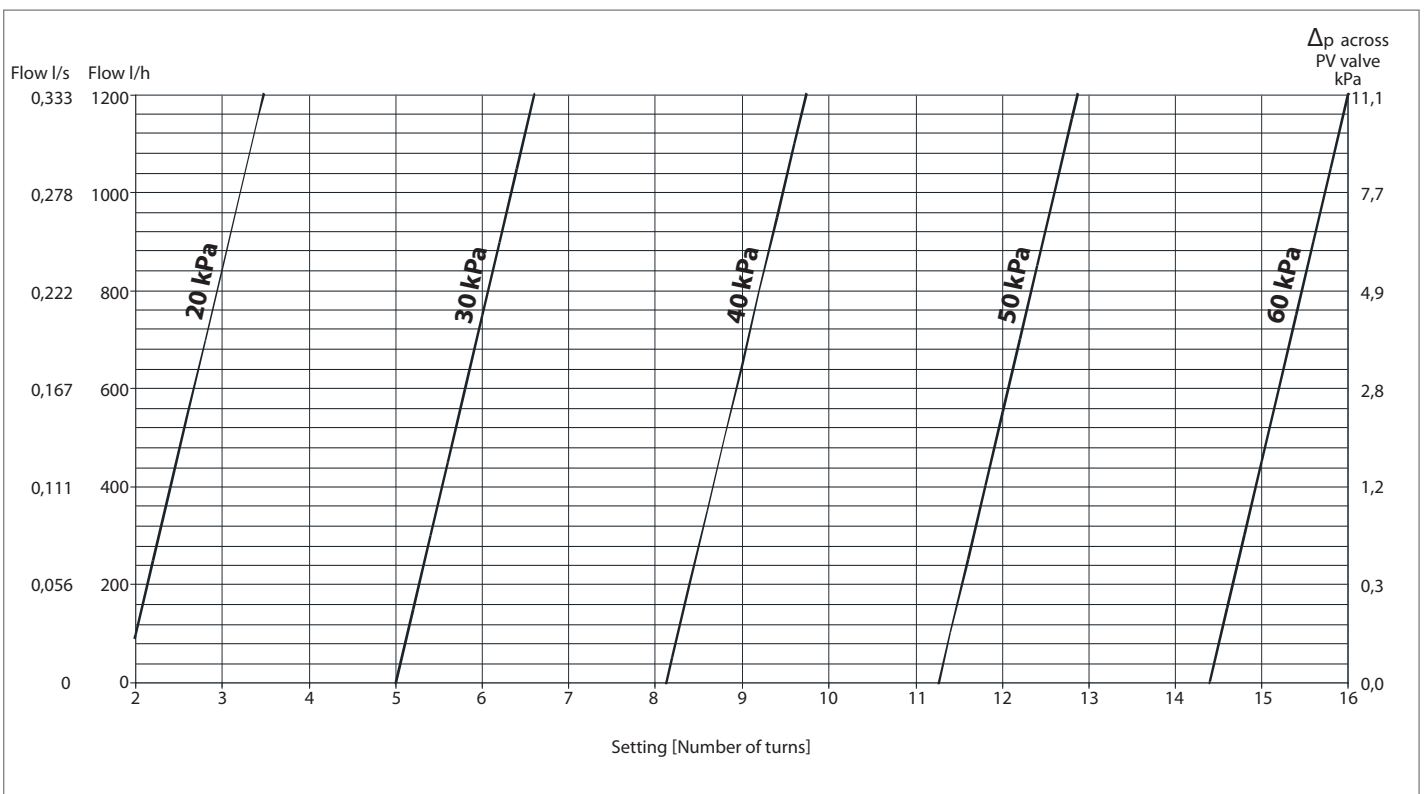

Frese PV - adjustable differential pressure control valve

Frese PV DN20, 5-30 kPa

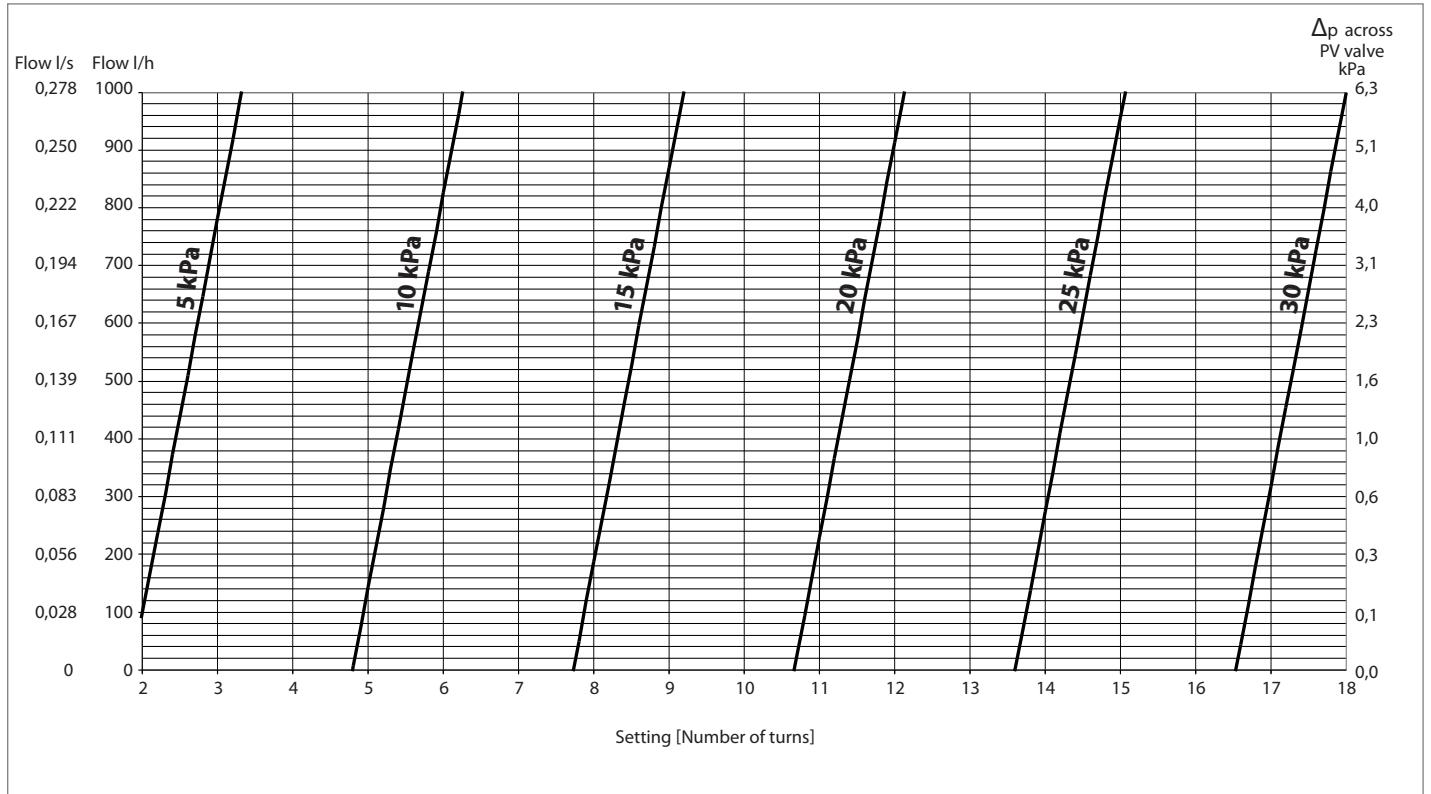

Frese PV DN20, 20-60 kPa

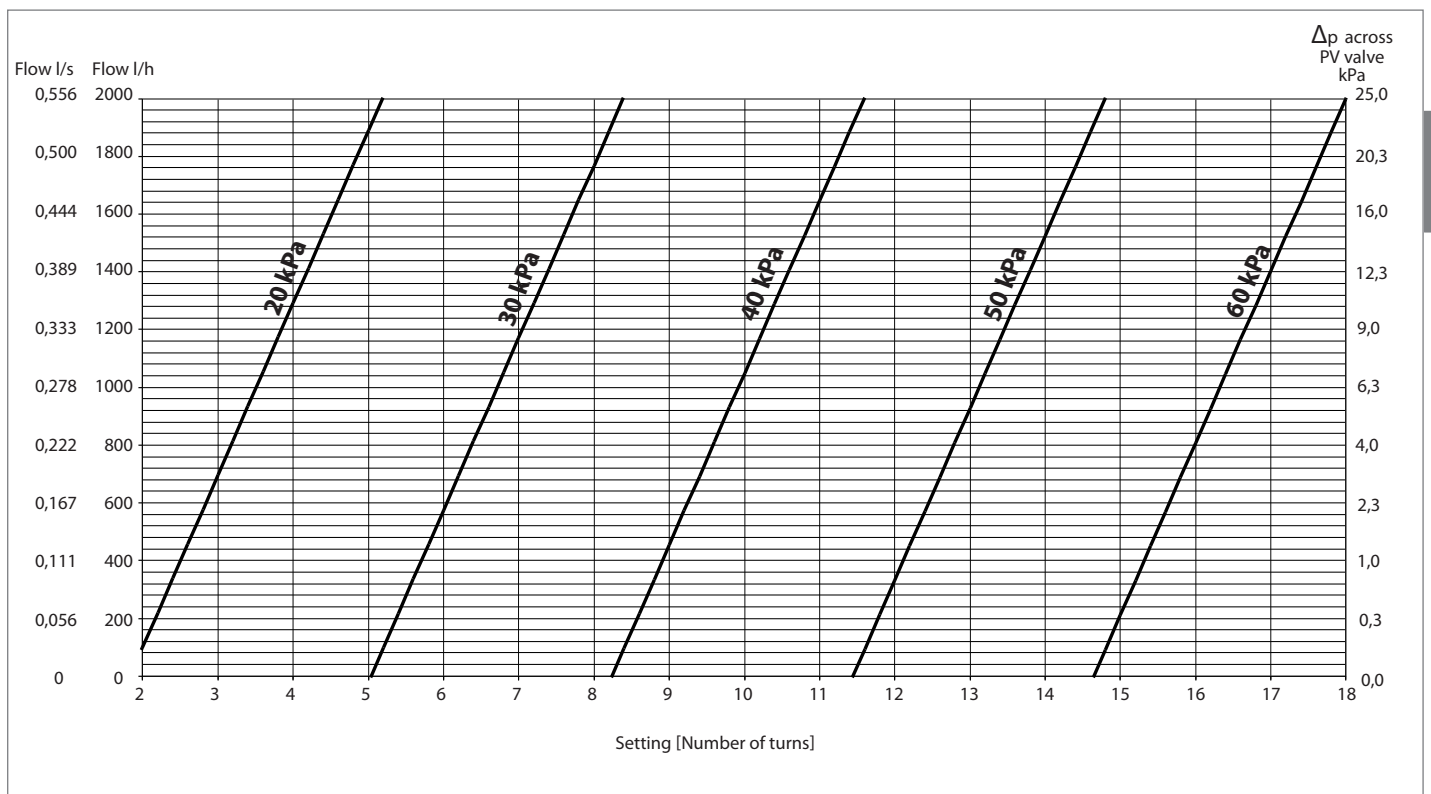

Frese PV

- adjustable differential pressure control valve

Frese PV DN25, 5-30 kPa

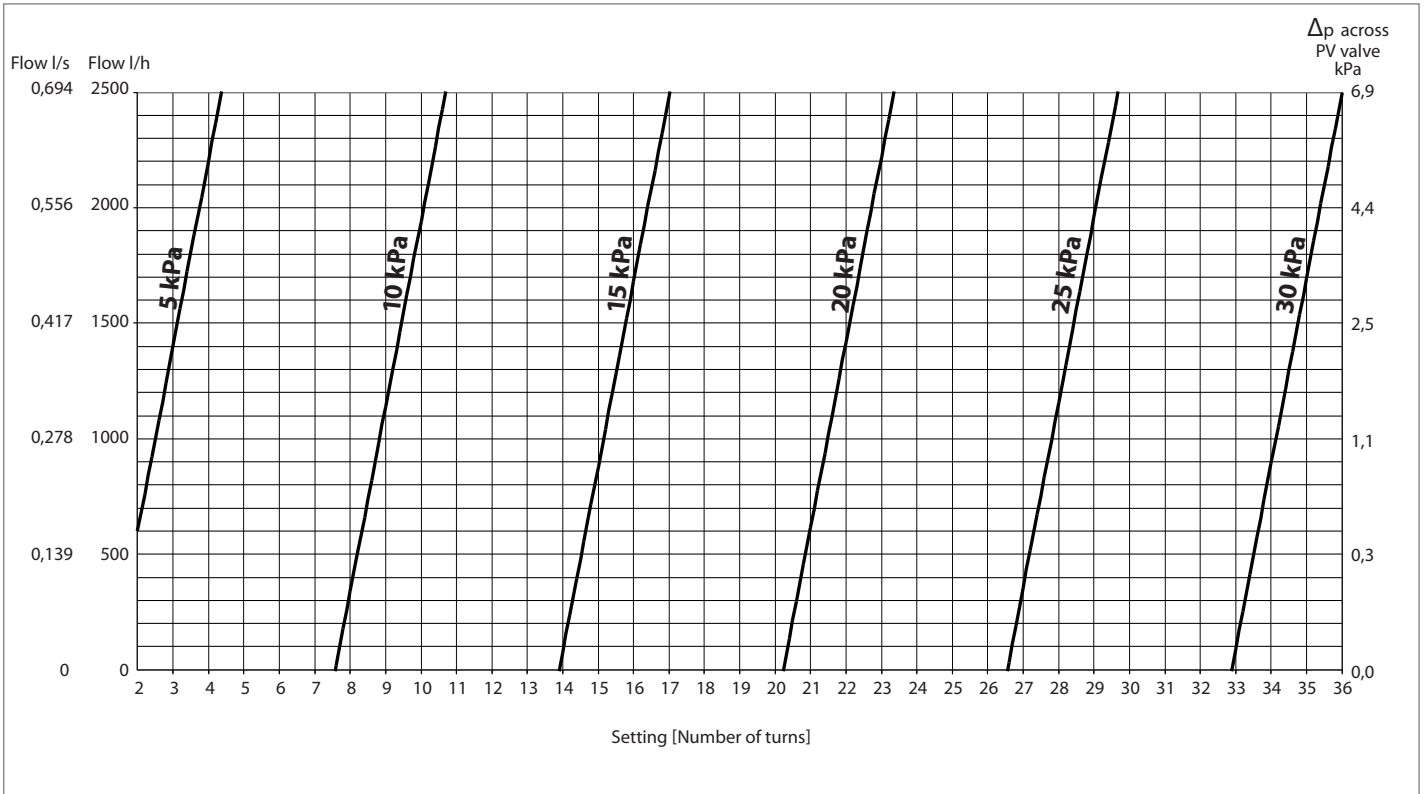

Frese PV DN25, 20-60 kPa

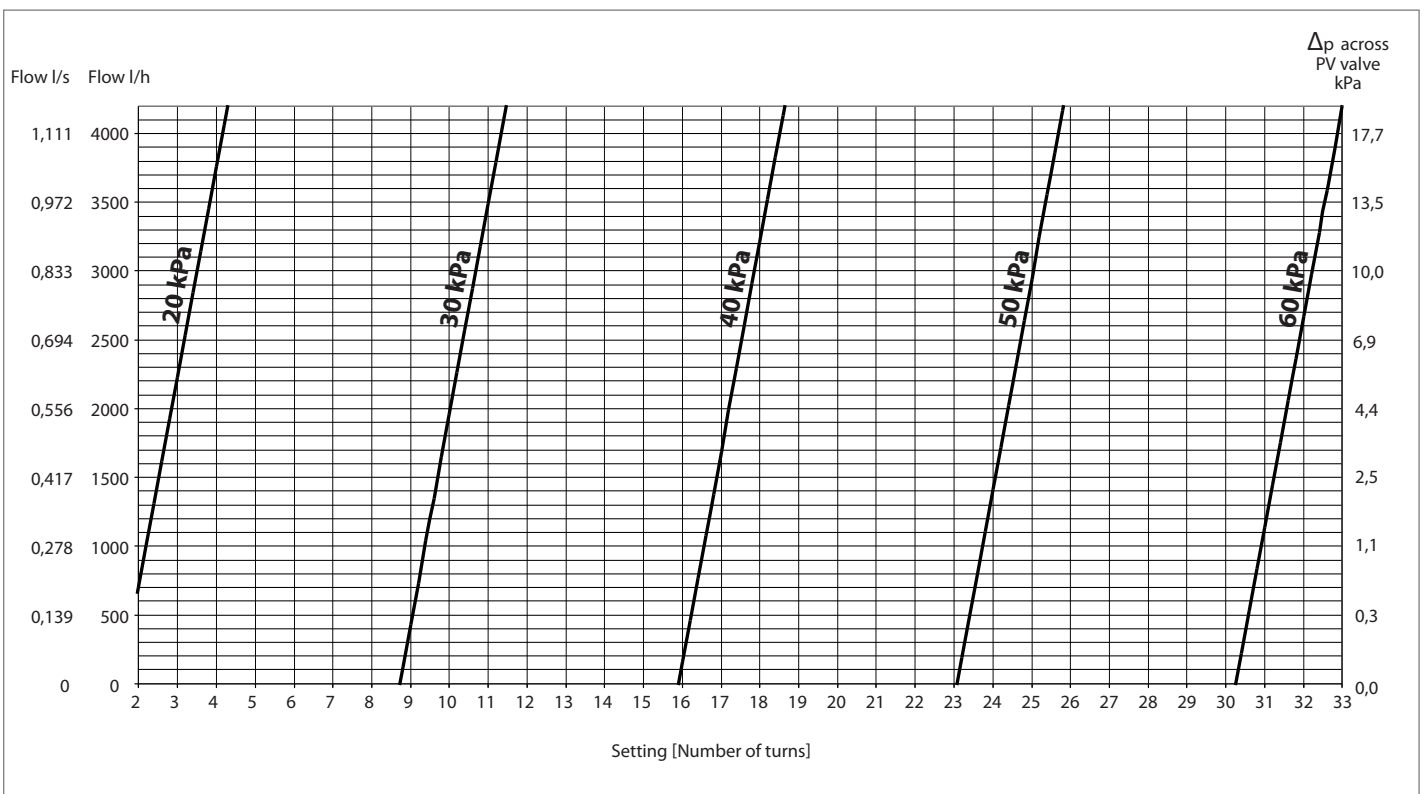

Frese PV - adjustable differential pressure control valve

Frese PV DN32, 20-80 kPa

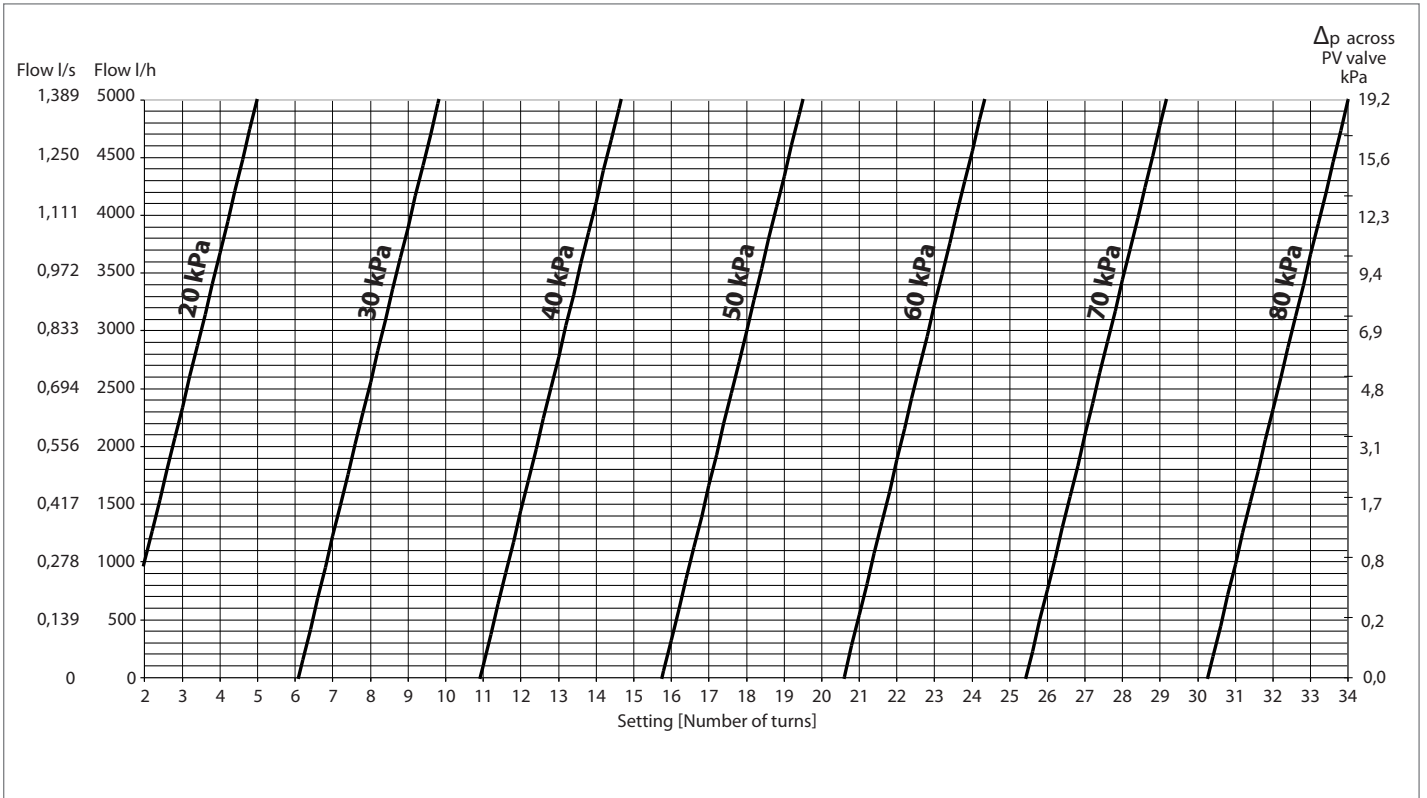

Frese PV DN40, 20-80 kPa

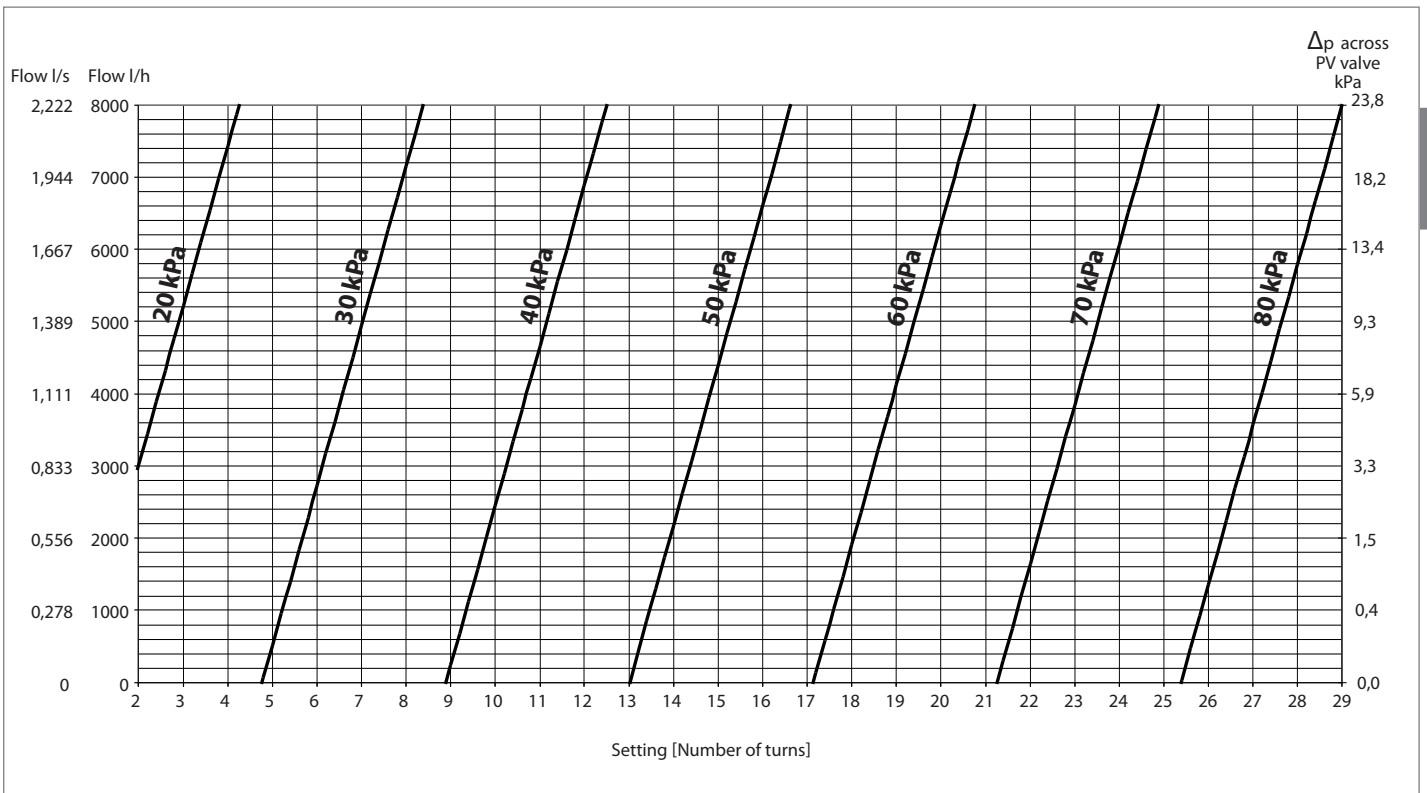

Frese PV - adjustable differential pressure control valve

Frese PV DN50, 20-80 kPa

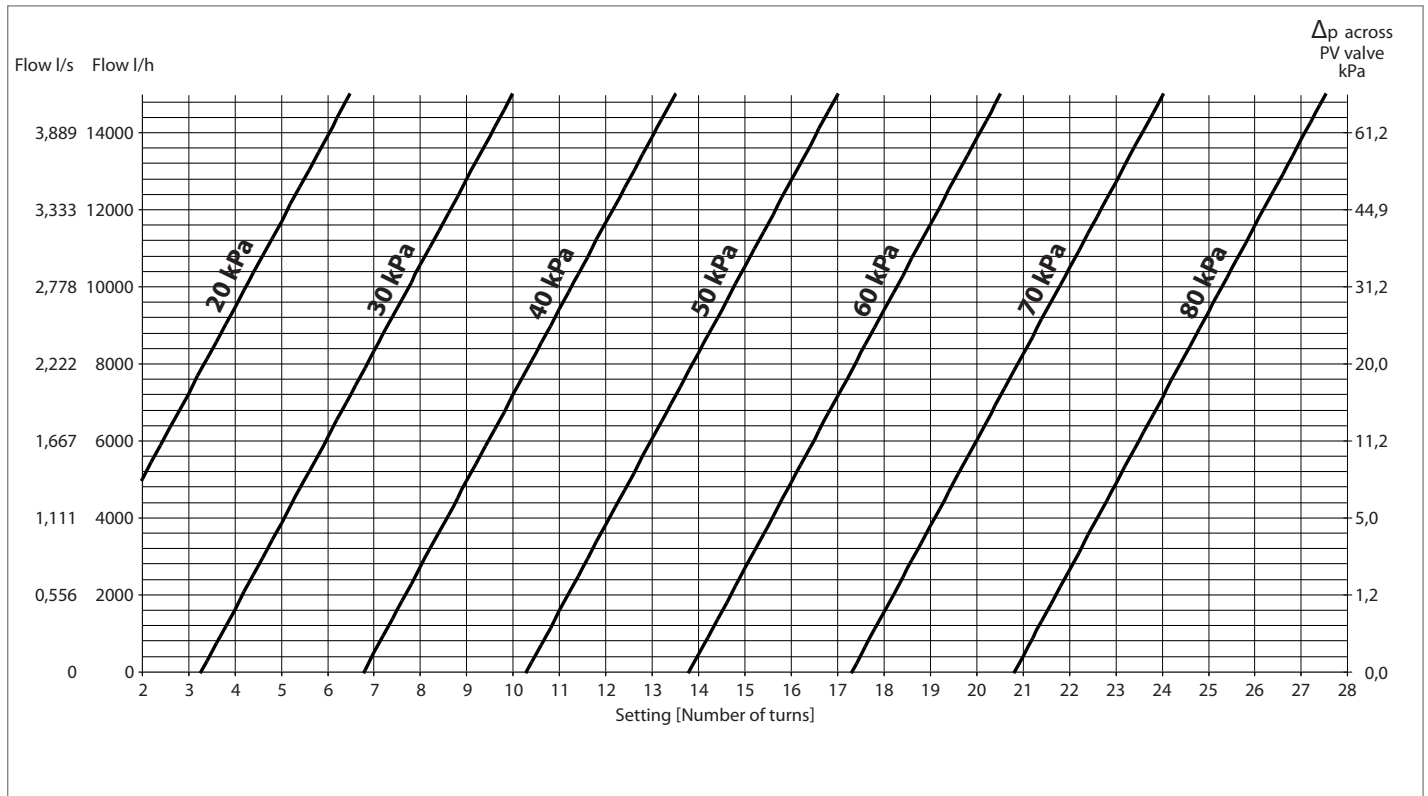

Text for technical specifications

The valve should be a dynamic difference control valve with the option of setting the differential pressure on site without suspension of operation.

The valve should limit the differential pressure in a circuit.

The valve should include optional P/T plugs for the verification of differential pressure in circuit and across the valve.

The valve scale should only be adjustable by means of a key.

The valve should be permanently marked with an indicator for flow direction.

Pressure rating PN16.

Frese PV - adjustable differential pressure control valve

Documentation formular

Valve ID (own choice)	Valve type	Dimension	Pre-setting	Verified Δp [kPa]	Min. Δp (see flow rate graph) [kPa]	Flow

Pump type	Regulation mode	Set point
-----------	-----------------	-----------

Installation

Signature	Date
-----------	------

EN Frese PV AUG 13

Frese A/S assumes no responsibility for errors, if any, in catalogues, brochures, and other printed matter. Frese A/S reserves the right to modify its products without prior notice, including already ordered products, if this does not alter existing specifications. All registered trademarks in this material are the property of Frese A/S. All rights reserved.

Frese A/S
Sorøvej 8
DK- 4200 Slagelse
Tel: +45 58 56 00 00
Fax: +45 58 56 00 91
info@frese.dk

