

OPTIMA Compact

Veriflow, Standard- & Ultra-series, DN50-DN300

Application

OPTIMA Compact, Veriflow, pressure independent balancing & control valve (PIBCV) is used in heating and cooling systems in applications with Air Handling Units, Heat Exchangers or Mixing Circuits.

OPTIMA Compact combines an externally adjustable automatic balancing valve with an integrated differential pressure controller and a full authority modulating control valve. It provides modulating control with full authority regardless of any fluctuations in the differential pressure of the system.

OPTIMA Compact makes it simple to achieve 100 % control of the water flow in the building, while creating high comfort and energy savings at the same time.

The Veriflow valve design with 3 P/T plugs allows for both flow measurement and verification of minimum differential pressure across the total valve for optimal pump energy saving.

OPTIMA Compact, Veriflow, is offered in 2 series:

- The Ultra-series has reduced size and weight to offer an easy installation
- The Standard-series has higher flows to cover a wider flow range

Benefits

Design

- Less time to define the necessary equipment for a hydraulic balanced system (only flow data are required)
- No need to calculate valve authority - always one
- Flexibility if the system is modified after the initial installation

Installation

- Lower weight and smaller outer dimensions makes installation easier
- More flow variants to match the required flows in the application
- No further regulating valves required in the distribution pipework when OPTIMA Compact is installed at the units
- Total number of valves minimized due to the 3-in-1 design
- Minimized commissioning time due to automatic balancing of the system
- No minimum straight pipe lengths required before or after the valve

Operation

- High comfort for the end-users due to high precision temperature control
- Longer life due to less movements of the actuator



Features

- Measurement of flow and minimum differential pressure due to valve design with 3 P/T plugs
- The presetting function has no impact on the stroke; Full stroke modulation at all times, regardless the preset flow
- Regulation characteristic remains unchanged regardless of preset flow
- The constant differential pressure across the modulating control component guarantees 100 % authority
- Automatic balancing eliminates overflows, regardless of fluctuating pressure conditions in the system
- Motoric actuator 0-10 V and 3 point control
- Differential pressure operating range up to 800 kPa
- Minimal required differential pressure due to advanced design of the valve
- Small dimensions due to compact housing
- Higher presetting precision due to stepless analogue scale
- Rangeability > 100:1

OPTIMA Compact

Veriflow, Standard- & Ultra-series, DN50-DN300

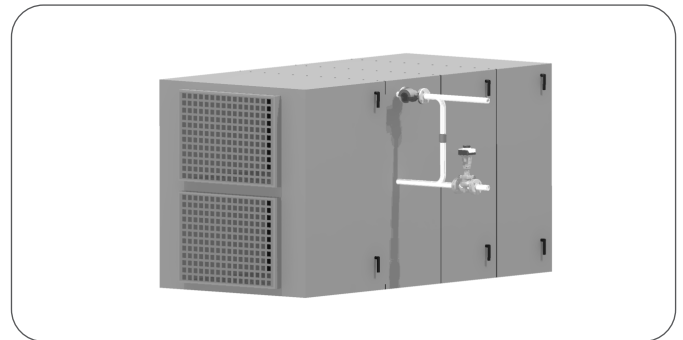
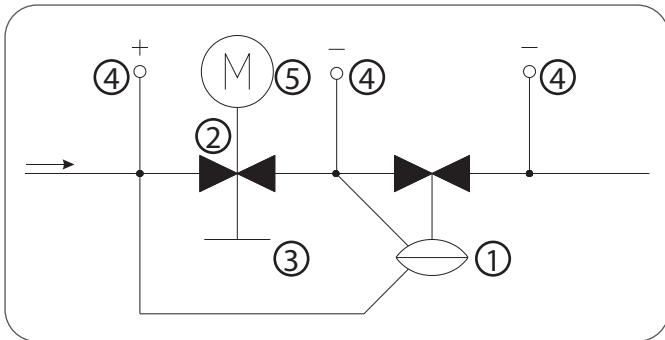

Design

The design of OPTIMA Compact combines high performance and a compact design.

The main components of the valve are:

- ① Differential pressure control
- ② Modulating control component
- ③ Presetting scale
- ④ P/T Plugs
- ⑤ Actuator

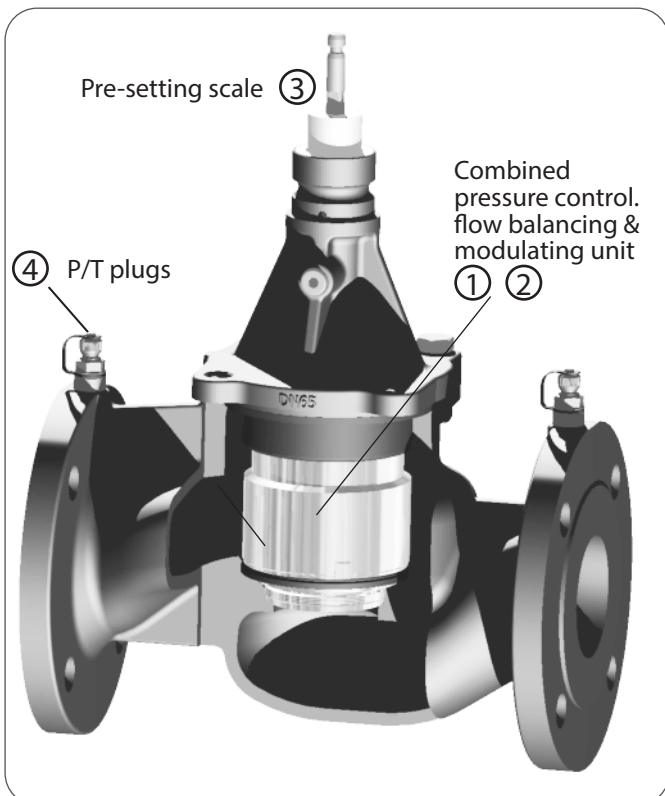
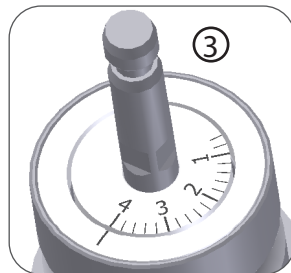

Function

OPTIMA Compact can be flushed and commissioned before the actuator is installed.

The presetting of the dial is user-friendly requiring only a simple flow vs. presetting table.

Once the flow is set, the actuator can be mounted and the valve ready to operate.

For lowest energy consumption, check the differential pressure at the index valve to set the pump at minimum speed.

Operating Pressure

OPTIMA Compact (DN50 to DN300) can operate to a maximum differential pressure of 800 kPa (8 bar).

Close Off Pressure

OPTIMA Compact is capable of closing against the following differential pressure to EN 1349 Class IV:

- DN50 to DN125: 800 kPa - based on 800 N actuator force.
- DN150 to DN200: 800 kPa - based on 1100 N actuator force.
- DN250 to DN300: 800 kPa - based on 2000 N actuator force.

Manual Operation

Actuators

The actuators can be operated by the manual handle. (5)



OPTIMA Compact

Veriflow, Standard- & Ultra-series, DN50-DN300

Operation principle

The innovative design of OPTIMA Compact features a modulating control component that retains 100% authority at all times.

With the OPTIMA Compact there are two independent movements for the presetting and the modulating function. During presetting, the inlet area moves radially without interfering with the length of the stroke. During modulating, the inlet area moves axial taking advantage of the full stroke.

Whilst the control component provides proportional modulation irrespective of the preset flow, the automatic balancing guarantees that the flow will never exceed the maximum preset flow.

Regardless of pressure fluctuations in the system, the maximum flow is kept constant up to a maximum differential pressure of 800 kPa.

Flow rate vs. Differential Pressure

Preset flow: 24000 I/h. 12000 I/h

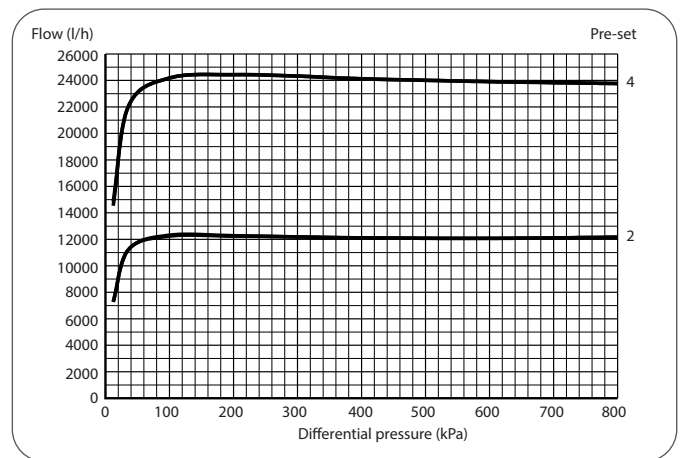

Flow rate vs. Voltage

Preset flow: 25000 I/h

Valve Characteristic:

The OPTIMA Compact valve design has a linear control characteristic. The control characteristic is independent of the flow setting and available pressure.

Because of the independent characteristic the actuator setting can be used to change the valve response from linear to logarithmic (Equal Percentage).

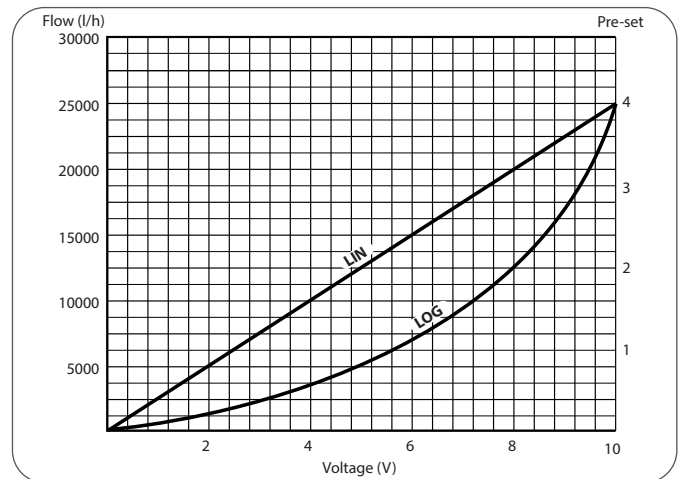

Flow rate vs. Differential Pressure

Voltage: 10 V. 7 V. 3 V
(Linear actuator characteristic)

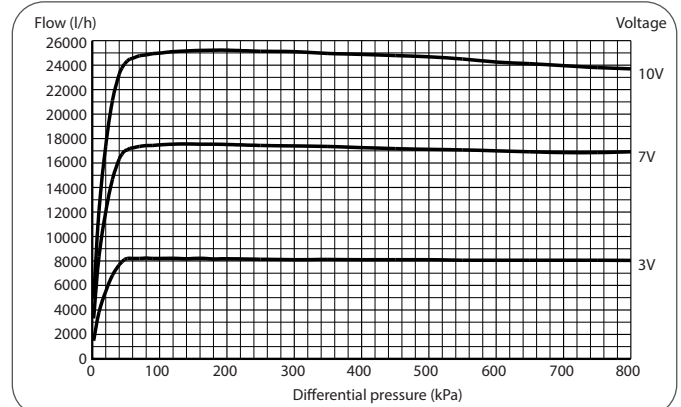

OPTIMA Compact

Veriflow, Standard- & Ultra-series, DN50-DN300

OPTIMA Compact Veriflow design for flow and pressure measurement

Flow measurement

To measure the flow, insert the needles from a manometer in the red P/T plug (P1) and in the blue P/T plug (P2) placed at the middle of the valve body.

Now the manometer measures the differential pressure (P1-P2) across the KV presetting and the flow can be calculated by the formulars below.

Please use the KV-signal values from the tables page 10-14

Flow Calculation

$Q = K_v \cdot \sqrt{\Delta p}$	$Q = \text{m}^3/\text{h}$ $\Delta p = \text{Bar}$
$Q = K_v \cdot 100 \cdot \sqrt{\Delta p}$	$Q = \text{l/h}$ $\Delta p = \text{kPa}$
$Q = \frac{K_v}{36} \cdot \sqrt{\Delta p}$	$Q = \text{l/s}$ $\Delta p = \text{kPa}$

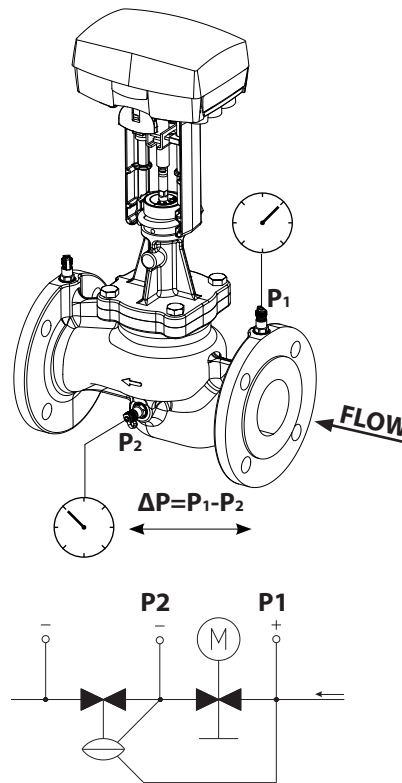

Minimum ΔP measurement

To measure the minimum differential pressure, insert the needles from a manometer in the red P/T plug (P1) and in the blue P/T plug (P3) placed at the outlet flange.

Now the manometer measures the differential pressure (P1-P3) across the total valve and the pump pressure can be optimized for pump energy saving.

Please use the required minimum differential pressure for the nominal flow in the tables page 10-14, or use the Frese APP.

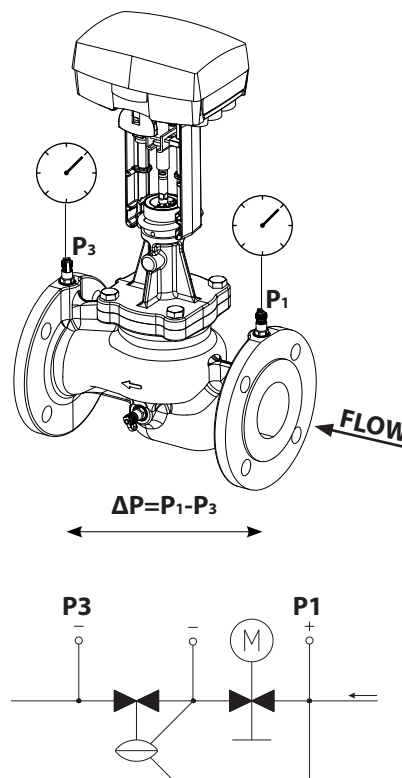

OPTIMA Compact

Veriflow, Standard- & Ultra-series, DN50-DN300

Technical data · DN50 - DN80

Valve housing:	GJL-250/GJS-400
Valve cover:	GJS-400
DN50 Ultra:	DZR brass CW602N
DP controller:	Stainless steel/PPS
Spring:	Stainless steel
Diaphragm:	Reinforced EPDM/HNBR
O-rings:	EPDM
Pressure class:	PN16/25
Stroke:	20 mm
DN50 Ultra:	15 mm
Flange connections:	ISO 7005-2 / EN 1092-2
Max. differential pressure:	800 kPa
Needles for DP measurement:	Max diameter. $\varnothing 3.2$ mm Length. 25 - 40 mm
Medium temperature range:	0 °C to 120 °C
With stem heater mounted:	From -10 °C

The pipe system shall be properly ventilated to avoid risk of air pockets. Glycolic mixtures up to 50 % are applicable (both ethylene and propylene). Frese A/S can accept no responsibility if another actuator is used instead of the Frese actuator. Recommendation: Water treatment to VDI 2035.

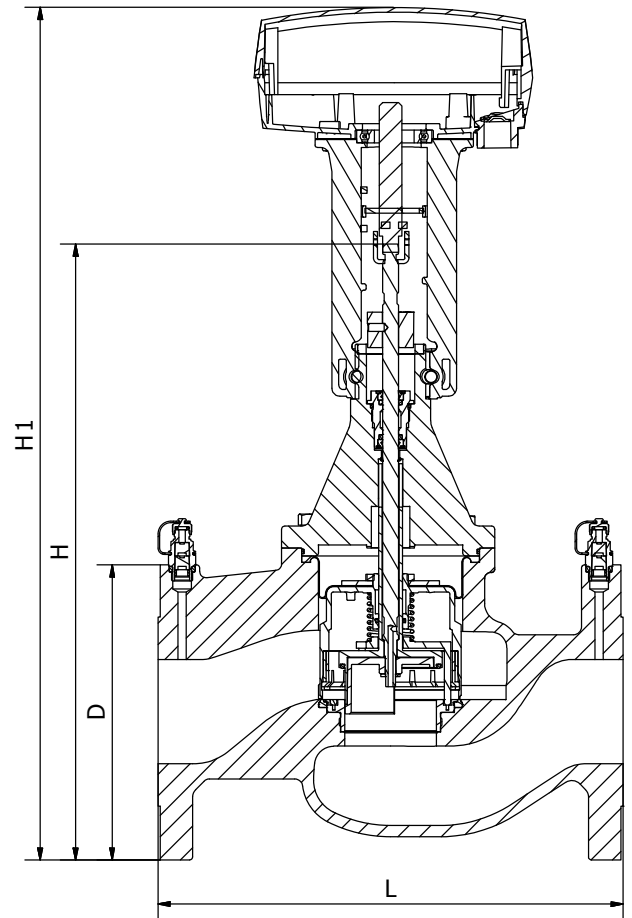

Dimension & Weight · DN50 - DN80

Valve Size		DN50		DN65		DN80	
Series		Ultra	Standard	Ultra	Standard	Ultra	Standard
Dimensions [mm]	L	230		290		310	
	H	233	367	367	384	384	413
	H1	340	508	508	525	525	554
	D	165		185		200	
Weight [kg]		10.7	14.5	17.2	19.2	23.6	27.5

OPTIMA Compact

Veriflow, Standard- & Ultra-series, DN50-DN300

Technical data · DN100 - DN150

- Valve housing:** GJL-250/GJS-400
- Valve cover:** GJS-400
- DP controller:** Stainless steel
- Spring:** Stainless steel
- Diaphragm:** Reinforced EPDM
- O-rings:** EPDM
- Pressure class:** PN16/25
- Stroke DN100-DN125:** 40 mm
- DN100 Ultra:** 20 mm
- Stroke DN150:** 43 mm
- Flange connections:** ISO 7005-2 / EN 1092-2
- Max. differential pressure:** 800 kPa
- Needles for DP measurement:** Max diameter. $\varnothing 3.2$ mm
Length. 25 - 40 mm
- Medium temperature range:**
- PN16 - DN100-DN150:** 0 °C to 120 °C
- PN25 - DN100-DN125:** 0 °C to 120 °C
- PN25 - DN150:** 0 °C to 110 °C
- With stem heater mounted:** From -10 °C

The pipe system shall be properly ventilated to avoid risk of air pockets. Glycolic mixtures up to 50 % are applicable (both ethylene and propylene). Frese A/S can accept no responsibility if another actuator is used instead of the Frese actuator. Recommendation: Water treatment to VDI 2035.

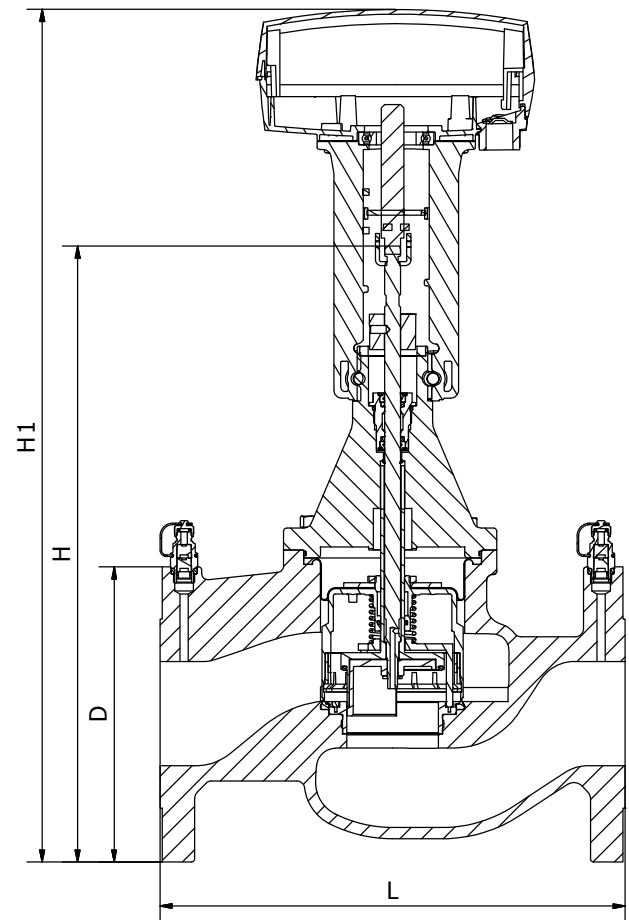

Dimension & Weight · DN100 - DN150

Valve Size		DN100		DN125		DN150
Series		Ultra	Standard	Ultra	Standard	Standard
Dimensions [mm]	L	350		400		480
	H	413	566	583	608	676
	H1	554	700	722	747	768
	D	235		270		285
Weight [kg]		41.2	50.1	63.1	77.2	111

OPTIMA Compact

Veriflow, Standard- & Ultra-series, DN50-DN300

Technical Data DN200 - DN300

Valve housing:	GJS-400
Valve cover:	GJS-400
DP controller:	Stainless steel
Spring:	Stainless steel
Diaphragm:	Reinforced EPDM
O-rings:	EPDM
Pressure class:	PN16/25
Stroke DN200:	43 mm
Stroke DN250-DN300:	48 mm
Flange connections:	ISO 7005-2/EN 1092-2
Max. differential pressure:	800 kPa
Needles for DP measurement:	Max diameter. $\varnothing 3.2$ mm Length. 25 - 40 mm
Medium temperature range:	
PN16 - DN200-DN300:	0 °C to 120 °C
PN25 - DN200-DN300:	0 °C to 110 °C
With stem heater mounted:	From -10 °C

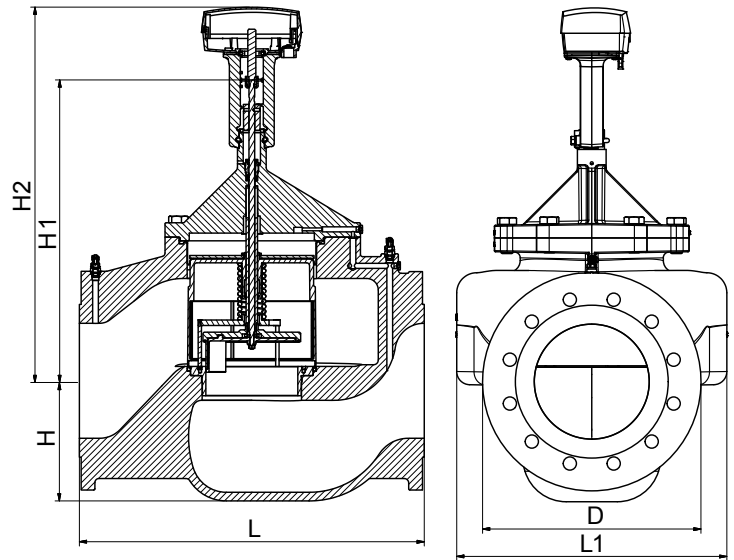

The pipe system shall be properly ventilated to avoid risk of air pockets. Glycolic mixtures up to 50 % are applicable (both ethylene and propylene). Frese A/S can accept no responsibility if another actuator is used instead of the Frese actuator. Recommendation: Water treatment to VDI 2035.

Dimension & Weight · DN200 - DN300

Valve Size		DN200	DN250	DN300
Series		Standard	Standard	Standard
Dimensions [mm]	L	600	730	850
	L1	470	549	719
	H	209	229	279
	H1	524	685	685
	H2	650	872	872
	D	380	444	520
Weight [kg]		175	307	470

OPTIMA Compact

Veriflow, Standard- & Ultra-series, DN50-DN300

Standard Actuators DN50 - DN300

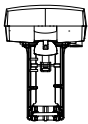
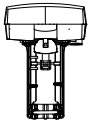
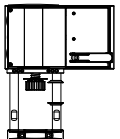
	Valve dimension	Control signal	Type [Item number]
	DN50 (Ultra-series)	0-10 V / 3-pos	-01 [53-1296]
	DN65 - DN125 (Ultra-series) DN50 - DN125 (Standard-series)	0-10 V / 3-pos	-02 [53-1297]
	DN150 - DN200 (Standard-series)	0-10 V / 3-pos	-03 [53-1298]
	DN250 - DN300 (Standard-series)	0-10 V/4-20 mA 3-pos / 2-pos	-10 [53-1299]

Spring Return Actuators DN50 - DN300

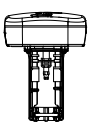
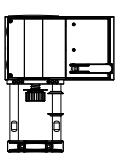
	Valve dimension	Control signal [Safty Function]	Type [Item number]
	DN50 (Ultra-series)	0-10 V / 3-pos [Stem up]	-04 [53-1950]
		0-10 V / 3-pos [Stem down]	-05 [53-1951]
	DN65 - DN125 (Ultra-series) DN50 - DN125 (Standard-series)	0-10 V / 3-pos [Stem up]	-06 [53-1952]
		0-10 V / 3-pos [Stem down]	-07 [53-1953]
	DN150 - DN300 (Standard-series)	0-10 V/4-20 mA 3-pos / 2-pos [Stem up]	-11 [53-1956]
		0-10 V/4-20 mA 3-pos / 2-pos [Stem down]	-12 [53-1957]

OPTIMA Compact valves can be ordered together with the actuator as one single item number.

Example: Valve item number 53-1200 together with actuator type -02 will have a combined item number: **53-1200-02**

Actuator specifications:

The full actuator range and detailed specifications can be found on the [OPTIMA Compact actuator WEB-page](#).

OPTIMA Compact

Veriflow, Standard- & Ultra-series, DN50-DN300

Product programme

Dim.	Series	Type	Flow [m ³ /h]	PN16	PN25
DN50	Ultra	High Flow	1.4 - 11.5	53-5081	53-5091
		Low Flow	2.5 - 15.0	53-5000	53-5020
	Standard	High Flow	3.9 - 24.0	53-5010	53-5030
DN65	Ultra	Low Flow	3.0 - 16.0	53-5082	53-5092
		High Flow	4.2 - 24.0	53-5083	53-5093
	Standard	Low Flow	4.4 - 25.0	53-5001	53-5021
		High Flow	5.9 - 35.0	53-5011	53-5031
DN80	Ultra	Low Flow	4.4 - 25.0	53-5084	53-5094
		High Flow	6.0 - 35.0	53-5085	53-5095
	Standard	Low Flow	5.3 - 34.0	53-5002	53-5022
		High Flow	7.0 - 43.0	53-5012	53-5032
DN100	Ultra	Low Flow	5.3 - 34.0	53-5086	53-5096
		High Flow	7.0 - 43.0	53-5087	53-5097
	Standard	Low Flow	12.1-68.0	53-5003	53-5023
		High Flow	14.8-90.0	53-5013	53-5033
DN125	Ultra	Low Flow	12.1-68.0	53-5088	53-5098
		High Flow	14.8-90.0	53-5089	53-5099
	Standard	Low Flow	18.5-110	53-5004	53-5024
		High Flow	23.0-135	53-5014	53-5034
DN150	Standard	Low Flow	25.6-148	53-5005	53-5025
		High Flow	32.0-195	53-5015	53-5035
DN200	Standard	Low Flow	95.0 - 210	53-5006	53-5026
		High Flow	130 - 280	53-5016	53-5036
DN250	Standard	Low Flow	190 - 475	53-5007	53-5027
		High Flow	245 - 600	53-5017	53-5037
DN300	Standard	Low Flow	190 - 475	53-5008	53-5028
		High Flow	245 - 600	53-5018	53-5038

The valve can be ordered with a protective coating in C5 standard. The product will have the item code extension - **ST01**.
Example: OPTIMA Compact Veriflow DN65 Standard PN16 Low Flow with C5 coating has item code **53-5001-ST01**

Accessories

Frese no.	Product	Type	Suitable for valves	Suitable for actuators
58-8951	Stem heater	24 VAC, 50 W	DN40-DN200	Type-01 to Type-07

OPTIMA Compact

Veriflow, Standard- & Ultra-series, DN50-DN300

Setting and Flow

Series Dim.	Ultra DN50 HF				
	Pre-set	Flow m ³ /h	Flow l/s	Flow gpm	Min.Δp kPa
0.6	1.40	0.389	6.16	10	4.66
0.8	1.71	0.474	7.52	11	5.87
1.0	2.05	0.569	9.03	11	7.11
1.2	2.42	0.673	10.7	11	8.34
1.4	2.82	0.783	12.4	11	9.54
1.6	3.24	0.900	14.3	12	10.7
1.8	3.68	1.02	16.2	12	11.7
2.0	4.15	1.15	18.3	13	12.7
2.2	4.64	1.29	20.5	14	13.6
2.4	5.17	1.44	22.8	16	14.4
2.6	5.73	1.59	25.2	17	15.1
2.8	6.34	1.76	27.9	20	15.8
3.0	7.00	1.94	30.8	22	16.5
3.2	7.72	2.15	34.0	25	17.2
3.4	8.52	2.37	37.5	28	18.0
3.6	9.40	2.61	41.4	30	18.9
3.8	10.4	2.89	45.8	33	20.0
4.0	11.5	3.19	50.6	36	21.4

Series Dim.	Standard									
	DN50 LF					DN50 HF				
Pre-set	Flow m ³ /h	Flow l/s	Flow gpm	Min.Δp kPa	KV-signal	Flow m ³ /h	Flow l/s	Flow gpm	Min.Δp kPa	KV-signal
0.6	2.50	0.689	10.9	7	9.19	3.90	1.09	17.3	19	9.68
0.8	3.20	0.887	14.1	7	11.7	5.10	1.41	22.3	19	11.9
1.0	3.90	1.07	17.0	7	13.9	6.20	1.71	27.2	19	14.1
1.2	4.50	1.25	19.8	7	15.9	7.20	2.00	31.8	19	16.2
1.4	5.10	1.42	22.5	7	17.7	8.20	2.29	36.2	19	18.2
1.6	5.70	1.59	25.1	7	19.5	9.20	2.56	40.6	20	20.1
1.8	6.30	1.75	27.7	8	21.1	10.2	2.83	44.9	20	22.0
2.0	6.90	1.92	30.4	8	22.8	11.2	3.11	49.2	21	23.9
2.2	7.50	2.08	33.0	9	24.5	12.2	3.39	53.7	22	25.7
2.4	8.10	2.26	35.8	9	26.2	13.2	3.67	58.2	24	27.6
2.6	8.80	2.44	38.7	10	27.9	14.3	3.97	62.9	25	29.3
2.8	9.50	2.64	41.8	11	29.6	15.4	4.28	67.9	27	31.0
3.0	10.2	2.84	45.0	12	31.4	16.6	4.61	73.1	30	32.7
3.2	11.0	3.07	48.6	13	33.2	17.9	4.97	78.7	33	34.3
3.4	11.9	3.31	52.4	15	34.9	19.2	5.35	84.7	36	35.7
3.6	12.8	3.57	56.6	16	36.6	20.7	5.75	91.2	40	37.0
3.8	13.9	3.86	61.1	18	38.2	22.3	6.19	98.1	45	38.2
4.0	15.0	4.17	66.0	20	39.6	24.0	6.67	106	50	39.1

Series Dim.	Ultra									
	DN65 LF					DN65 HF				
Pre-set	Flow m ³ /h	Flow l/s	Flow gpm	Min.Δp kPa	KV-signal	Flow m ³ /h	Flow l/s	Flow gpm	Min.Δp kPa	KV-signal
0.6	3.00	0.833	13.2	10	9.89	4.20	1.17	18.5	19	9.44
0.8	3.80	1.06	16.7	10	12.3	5.48	1.52	24.1	19	11.9
1.0	4.50	1.25	19.8	10	14.4	6.60	1.83	29.1	19	14.0
1.2	5.13	1.43	22.6	10	16.3	7.60	2.11	33.5	19	15.9
1.4	5.73	1.59	25.2	10	18.0	8.53	2.37	37.6	19	17.7
1.6	6.31	1.75	27.8	11	19.7	9.42	2.62	41.5	20	19.5
1.8	6.89	1.92	30.4	11	21.5	10.3	2.86	45.4	20	21.2
2.0	7.50	2.08	33.0	11	23.4	11.2	3.11	49.3	20	22.9
2.2	8.14	2.26	35.8	11	25.4	12.1	3.37	53.4	20	24.7
2.4	8.83	2.45	38.9	11	27.5	13.1	3.65	57.8	21	26.5
2.6	9.56	2.66	42.1	11	29.8	14.2	3.95	62.5	22	28.3
2.8	10.4	2.88	45.6	12	32.2	15.4	4.27	67.6	23	30.1
3.0	11.2	3.11	49.3	12	34.6	16.6	4.61	73.1	24	32.0
3.2	12.1	3.36	53.3	13	37.0	17.9	4.98	78.9	26	33.8
3.4	13.0	3.62	57.4	13	39.3	19.3	5.37	85.2	29	35.5
3.6	14.0	3.89	61.7	15	41.4	20.8	5.79	91.7	32	37.1
3.8	15.0	4.17	66.1	17	43.1	22.4	6.22	98.6	37	38.3
4.0	16.0	4.44	70.4	19	44.4	24.0	6.67	106	43	39.3

OPTIMA Compact

Veriflow, Standard- & Ultra-series, DN50-DN300

Setting and Flow

Series		Standard								
Dim.	DN65 LF					DN65 HF				
Pre-set	Flow m ³ /h	Flow l/s	Flow gpm	Min.Δp kPa	KV-signal	Flow m ³ /h	Flow l/s	Flow gpm	Min.Δp kPa	KV-signal
0.6	4.40	1.22	19.3	15	11.6	6.00	1.65	26.2	30	10.9
0.8	5.60	1.54	24.5	15	14.8	7.60	2.11	33.4	30	13.6
1.0	6.60	1.85	29.3	15	17.5	9.10	2.53	40.1	30	16.0
1.2	7.70	2.13	33.7	16	19.9	10.5	2.93	46.4	31	18.2
1.4	8.60	2.40	38.0	17	22.1	11.9	3.31	52.5	32	20.4
1.6	9.60	2.66	42.2	17	24.3	13.3	3.69	58.5	32	22.6
1.8	10.5	2.93	46.4	18	26.4	14.7	4.07	64.5	32	24.9
2.0	11.5	3.20	50.6	18	28.6	16.0	4.46	70.7	32	27.3
2.2	12.5	3.47	55.0	18	30.9	17.5	4.86	77.0	32	29.9
2.4	13.5	3.76	59.6	19	33.3	19.0	5.28	83.6	32	32.6
2.6	14.7	4.07	64.5	19	35.9	20.6	5.72	90.6	33	35.5
2.8	15.8	4.40	69.7	19	38.6	22.3	6.19	98.1	34	38.5
3.0	17.1	4.75	75.3	20	41.4	24.1	6.69	106	35	41.5
3.2	18.5	5.13	81.3	21	44.2	26.0	7.22	114	37	44.5
3.4	19.9	5.54	87.8	21	47.0	28.0	7.79	123	40	47.4
3.6	21.5	5.98	94.7	22	49.6	30.2	8.40	133	44	50.1
3.8	23.2	6.45	102	24	52.0	32.5	9.04	143	49	52.5
4.0	25.0	6.95	110	25	54.0	35.0	9.72	154	55	54.3

Series		Ultra								
Dim.	DN80 LF					DN80 HF				
Pre-set	Flow m ³ /h	Flow l/s	Flow gpm	Min.Δp kPa	KV-signal	Flow m ³ /h	Flow l/s	Flow gpm	Min.Δp kPa	KV-signal
0.6	4.40	1.22	19.4	15	10.4	6.00	1.67	26.4	27	10.8
0.8	5.53	1.54	24.4	15	12.8	7.61	2.11	33.5	27	13.2
1.0	6.60	1.83	29.1	15	15.2	9.10	2.53	40.1	27	15.5
1.2	7.61	2.12	33.5	15	17.5	10.5	2.92	46.3	27	17.9
1.4	8.60	2.39	37.8	16	19.9	11.9	3.30	52.3	27	20.2
1.6	9.56	2.66	42.1	17	22.2	13.2	3.68	58.3	27	22.7
1.8	10.5	2.92	46.3	17	24.5	14.6	4.06	64.3	27	25.1
2.0	11.5	3.19	50.6	18	26.9	16.0	4.44	70.4	27	27.6
2.2	12.5	3.47	55.1	19	29.3	17.4	4.85	76.8	27	30.1
2.4	13.6	3.77	59.7	19	31.7	19.0	5.27	83.5	28	32.7
2.6	14.7	4.07	64.6	19	34.2	20.6	5.72	90.6	29	35.2
2.8	15.8	4.40	69.7	20	36.8	22.3	6.19	98.1	30	37.8
3.0	17.1	4.75	75.3	20	39.4	24.1	6.69	106	32	40.4
3.2	18.5	5.13	81.2	20	42.1	26.0	7.23	115	35	42.9
3.4	19.9	5.53	87.7	21	44.9	28.1	7.80	124	38	45.4
3.6	21.5	5.97	94.6	22	47.9	30.3	8.41	133	42	47.8
3.8	23.2	6.44	102	23	50.9	32.6	9.05	143	48	50.1
4.0	25.0	6.94	110	25	54.1	35.0	9.72	154	55	52.3

Series		Standard								
Dim.	DN80 LF					DN80 HF				
Pre-set	Flow m ³ /h	Flow l/s	Flow gpm	Min.Δp kPa	KV-signal	Flow m ³ /h	Flow l/s	Flow gpm	Min.Δp kPa	KV-signal
0.6	5.30	1.48	23.5	16	14.9	7.00	1.95	30.9	23	15.0
0.8	6.90	1.91	30.2	16	18.8	9.00	2.51	39.8	23	19.9
1.0	8.30	2.30	36.5	16	22.4	11.0	3.04	48.2	23	24.0
1.2	9.60	2.68	42.4	17	25.8	12.8	3.55	56.2	24	27.5
1.4	10.9	3.04	48.2	17	29.1	14.5	4.03	63.9	24	30.6
1.6	12.2	3.40	53.8	17	32.5	16.2	4.51	71.5	24	33.7
1.8	13.5	3.75	59.5	18	35.8	18.0	4.98	79.0	25	36.7
2.0	14.8	4.11	65.2	18	39.2	19.6	5.46	86.5	25	39.9
2.2	16.2	4.49	71.1	18	42.7	21.4	5.94	94.2	25	43.3
2.4	17.6	4.88	77.3	19	46.3	23.2	6.45	102	26	46.9
2.6	19.1	5.30	83.9	19	50.0	25.1	6.97	111	27	50.8
2.8	20.7	5.74	91.0	19	53.9	27.1	7.53	119	28	54.9
3.0	22.4	6.23	98.7	20	57.7	29.3	8.13	129	30	59.1
3.2	24.3	6.76	107	21	61.5	31.6	8.78	139	33	63.2
3.4	26.4	7.34	116	21	65.3	34.1	9.47	150	36	67.2
3.6	28.7	7.98	126	22	68.9	36.8	10.2	162	40	70.7
3.8	31.2	8.68	138	24	72.2	39.8	11.1	175	44	73.5
4.0	34.0	9.45	150	25	75.2	43.0	12.0	189	50	75.4

OPTIMA Compact

Veriflow, Standard- & Ultra-series, DN50-DN300

Setting and Flow

Series		Ultra								
Dim.	DN100 LF					DN100 HF				
Pre-set	Flow m ³ /h	Flow l/s	Flow gpm	Min.Δp kPa	KV-signal	Flow m ³ /h	Flow l/s	Flow gpm	Min.Δp kPa	KV-signal
0.6	5.30	1.47	23.3	13	15.6	7.00	1.94	30.8	20	16.8
0.8	6.86	1.90	30.2	15	19.2	9.08	2.52	40.0	20	19.9
1.0	8.30	2.31	36.5	16	22.6	11.0	3.06	48.4	21	23.1
1.2	9.66	2.68	42.5	17	26.0	12.8	3.56	56.4	21	26.3
1.4	11.0	3.05	48.3	17	29.4	14.5	4.04	64.0	22	29.7
1.6	12.2	3.40	53.9	18	33.0	16.2	4.51	71.5	22	33.1
1.8	13.5	3.75	59.5	18	36.6	17.9	4.97	78.8	22	36.7
2.0	14.8	4.11	65.2	18	40.5	19.6	5.44	86.3	22	40.5
2.2	16.1	4.48	71.0	18	44.5	21.3	5.93	94.0	22	44.4
2.4	17.5	4.87	77.2	18	48.7	23.2	6.43	102	22	48.4
2.6	19.0	5.29	83.8	19	53.0	25.1	6.97	110	22	52.4
2.8	20.6	5.74	90.9	19	57.4	27.1	7.53	119	22	56.4
3.0	22.4	6.22	98.6	20	61.8	29.3	8.14	129	22	60.4
3.2	24.3	6.75	107	21	66.1	31.6	8.79	139	23	64.2
3.4	26.4	7.34	116	22	70.1	34.2	9.49	150	24	67.8
3.6	28.7	7.97	126	23	73.8	36.9	10.3	162	26	71.1
3.8	31.2	8.68	138	24	76.9	39.8	11.1	175	29	73.8
4.0	34.0	9.44	150	25	79.4	43.0	11.9	189	33	76.0

Series		Standard								
Dim.	DN100 LF					DN100 HF				
Pre-set	Flow m ³ /h	Flow l/s	Flow gpm	Min.Δp kPa	KV-signal	Flow m ³ /h	Flow l/s	Flow gpm	Min.Δp kPa	KV-signal
0.6	12.1	3.37	53.4	19	35.2	14.8	4.10	65.0	29	35.0
0.8	15.3	4.25	67.3	20	43.4	18.9	5.25	83.2	29	43.0
1.0	18.1	5.04	79.9	20	50.2	22.6	6.28	99.5	30	49.6
1.2	20.8	5.76	91.4	20	56.1	26.0	7.22	114	31	55.3
1.4	23.2	6.44	102	21	61.4	29.1	8.09	128	32	60.8
1.6	25.5	7.08	112	21	66.5	32.1	8.92	141	33	66.3
1.8	27.8	7.71	122	22	71.7	35.1	9.74	154	34	72.2
2.0	30.0	8.35	132	22	77.1	38.1	10.6	168	35	78.8
2.2	32.4	9.00	143	22	83.0	41.2	11.4	181	36	86.3
2.4	34.9	9.70	154	23	89.6	44.5	12.4	196	38	94.6
2.6	37.6	10.5	166	23	96.9	48.2	13.4	212	40	104
2.8	40.6	11.3	179	24	105	52.2	14.5	230	42	114
3.0	44.0	12.2	194	25	114	56.7	15.8	250	45	125
3.2	47.7	13.3	210	26	124	61.9	17.2	272	49	136
3.4	51.9	14.4	229	27	134	67.7	18.8	298	53	148
3.6	56.7	15.7	249	29	145	74.2	20.6	327	59	159
3.8	62.0	17.2	273	32	156	81.7	22.7	360	66	169
4.0	68.0	18.9	299	35	168	90.0	25.0	396	75	178

Series		Ultra								
Dim.	DN125 LF					DN125 HF				
Pre-set	Flow m ³ /h	Flow l/s	Flow gpm	Min.Δp kPa	KV-signal	Flow m ³ /h	Flow l/s	Flow gpm	Min.Δp kPa	KV-signal
0.6	12.1	3.36	53.3	15	32.4	14.8	4.11	65.2	22	30.4
0.8	15.3	4.24	67.2	18	39.4	18.9	5.25	83.2	22	38.3
1.0	18.1	5.03	79.7	20	45.7	22.6	6.28	99.5	22	45.9
1.2	20.7	5.75	91.1	21	51.4	26.0	7.22	114	22	53.2
1.4	23.1	6.42	102	22	56.9	29.1	8.09	128	22	60.2
1.6	25.4	7.07	112	22	62.2	32.2	8.93	142	22	67.0
1.8	27.7	7.70	122	22	67.7	35.1	9.75	155	22	73.7
2.0	30.0	8.33	132	22	73.4	38.1	10.6	168	22	80.4
2.2	32.4	8.99	143	22	79.4	41.2	11.4	181	22	87.2
2.4	34.9	9.69	154	22	85.9	44.5	12.4	196	22	94.2
2.6	37.6	10.5	166	23	92.8	48.2	13.4	212	23	102
2.8	40.6	11.3	179	24	100	52.2	14.5	230	24	109
3.0	44.0	12.2	194	25	108	56.7	15.7	250	25	118
3.2	47.8	13.3	210	27	116	61.8	17.2	272	27	127
3.4	52.0	14.4	229	28	125	67.6	18.8	298	30	138
3.6	56.7	15.8	250	30	134	74.1	20.6	326	33	150
3.8	62.0	17.2	273	33	142	81.6	22.7	359	38	164
4.0	68.0	18.9	299	35	151	90.0	25.0	396	44	179

OPTIMA Compact

Veriflow, Standard- & Ultra-series, DN50-DN300

Setting and Flow

Series	Standard									
	Dim.	DN125 LF					DN125 HF			
Pre-set	Flow m ³ /h	Flow l/s	Flow gpm	Min.Δp kPa	KV-signal	Flow m ³ /h	Flow l/s	Flow gpm	Min.Δp kPa	KV-signal
0.6	18.5	5.14	81.5	16	43.6	23.0	6.39	101	27	45.4
0.8	23.6	6.54	104	16	54.3	29.9	8.31	132	27	56.7
1.0	28.5	7.92	125	16	64.4	36.5	10.1	161	27	67.4
1.2	33.3	9.26	147	17	74.2	42.8	11.9	188	28	77.7
1.4	38.0	10.6	167	17	83.8	48.7	13.5	215	28	87.7
1.6	42.6	11.8	188	17	93.4	54.5	15.1	240	28	97.7
1.8	47.1	13.1	207	18	103	60.0	16.7	264	29	108
2.0	51.5	14.3	227	18	113	65.5	18.2	288	29	118
2.2	55.9	15.5	246	18	123	70.9	19.7	312	29	128
2.4	60.4	16.8	266	19	133	76.4	21.2	336	30	139
2.6	65.0	18.1	286	19	144	82.0	22.8	361	31	150
2.8	69.8	19.4	308	20	155	87.8	24.4	387	32	161
3.0	75.0	20.8	330	21	166	94.0	26.1	414	33	172
3.2	80.6	22.4	355	22	177	101	28.0	443	35	183
3.4	86.7	24.1	382	24	188	108	30.0	475	37	194
3.6	93.6	26.0	412	26	200	116	32.2	511	41	204
3.8	101	28.1	446	30	211	125	34.7	550	46	214
4.0	110	30.6	484	35	221	135	37.5	594	53	223

Series	Standard									
	Dim.	DN150 LF					DN150 HF			
Pre-set	Flow m ³ /h	Flow l/s	Flow gpm	Min.Δp kPa	KV-signal	Flow m ³ /h	Flow l/s	Flow gpm	Min.Δp kPa	KV-signal
0.6	25.6	7.11	113	21	60.8	32.0	8.89	141	33	59.8
0.8	32.6	9.05	143	21	77.0	41.3	11.5	182	33	76.1
1.0	39.2	10.9	173	21	92.3	50.0	13.9	220	33	91.6
1.2	45.6	12.7	201	21	107	58.2	16.2	256	33	106
1.4	51.8	14.4	228	21	121	66.0	18.3	291	33	121
1.6	58.0	16.1	255	21	134	73.7	20.5	324	33	134
1.8	64.1	17.8	282	21	147	81.3	22.6	358	33	148
2.0	70.4	19.6	310	22	160	89.0	24.7	392	34	161
2.2	76.8	21.3	338	23	173	96.9	26.9	427	36	174
2.4	83.4	23.2	367	25	185	105	29.2	463	38	186
2.6	90.3	25.1	398	27	197	114	31.6	501	40	199
2.8	97.5	27.1	429	28	209	123	34.2	542	43	211
3.0	105	29.2	462	30	221	133	36.9	586	46	223
3.2	113	31.3	497	32	232	144	39.9	632	49	235
3.4	121	33.6	533	33	243	155	43.1	683	53	246
3.6	130	36.0	571	34	253	167	46.5	737	57	257
3.8	139	38.5	610	35	263	181	50.2	796	61	267
4.0	148	41.1	652	35	271	195	54.2	859	65	277

Series	Standard									
	Dim.	DN200 LF					DN200 HF			
Pre-set	Flow m ³ /h	Flow l/s	Flow gpm	Min.Δp kPa	KV-signal	Flow m ³ /h	Flow l/s	Flow gpm	Min.Δp kPa	KV-signal
1.0	95	26.4	418	11	243	130	36.1	572	31	245
1.2	100	27.8	440	12	261	137	38.1	604	32	265
1.4	105	29.3	464	12	276	145	40.2	638	33	280
1.6	112	31.0	491	13	287	153	42.4	673	35	291
1.8	118	32.8	520	15	295	161	44.8	710	38	299
2.0	125	34.7	550	16	301	170	47.2	748	41	305
2.2	132	36.8	583	17	306	179	49.8	789	45	310
2.4	140	38.9	617	19	310	189	52.4	831	49	313
2.6	148	41.1	652	21	314	199	55.2	875	53	317
2.8	156	43.5	689	22	320	209	58.1	921	57	322
3.0	165	45.8	726	24	326	220	61.1	969	61	328
3.2	174	48.3	765	26	335	231	64.2	1018	65	337
3.4	183	50.7	804	27	346	243	67.4	1069	69	348
3.6	192	53.3	844	29	361	255	70.8	1122	72	364
3.8	201	55.8	884	31	380	267	74.2	1176	75	384
4.0	210	58.3	925	32	404	280	77.8	1233	78	409

OPTIMA Compact

Veriflow, Standard- & Ultra-series, DN50-DN300

Setting and Flow

Series	Standard									
	Dim.	DN250 LF					DN250 HF			
Pre-set	Flow m ³ /h	Flow l/s	Flow gpm	Min.Δp kPa	KV-signal	Flow m ³ /h	Flow l/s	Flow gpm	Min.Δp kPa	KV-signal
1.0	190	52.8	837	10	408	245	68.1	1079	15	428
1.2	205	57.0	904	10	418	256	71.2	1129	16	442
1.4	220	61.0	967	11	432	270	75.1	1190	17	456
1.6	233	64.8	1027	12	448	286	79.6	1261	20	470
1.8	247	68.5	1086	13	468	305	84.7	1342	22	484
2.0	260	72.2	1145	15	490	325	90.3	1431	25	498
2.2	274	76.0	1205	17	513	347	96.4	1528	28	533
2.4	288	80.1	1269	19	538	371	103	1632	32	567
2.6	304	84.4	1338	21	563	396	110	1743	36	597
2.8	321	89.2	1413	23	587	422	117	1860	40	626
3.0	340	94.4	1497	25	611	450	125	1981	45	652
3.2	361	100	1590	27	634	479	133	2107	50	676
3.4	385	107	1695	29	654	508	141	2237	55	697
3.6	412	114	1812	31	672	538	150	2370	60	717
3.8	441	123	1944	33	687	569	158	2505	65	733
4.0	475	132	2091	35	699	600	167	2642	70	748

Series	Standard									
	Dim.	DN300 LF					DN300 HF			
Pre-set	Flow m ³ /h	Flow l/s	Flow gpm	Min.Δp kPa	KV-signal	Flow m ³ /h	Flow l/s	Flow gpm	Min.Δp kPa	KV-signal
1.0	190	52.8	837	10	387	245	68.1	1079	15	397
1.2	205	57.0	904	10	419	256	71.2	1129	16	429
1.4	220	61.0	967	11	447	270	75.1	1190	17	457
1.6	233	64.8	1027	12	469	286	79.6	1261	20	481
1.8	247	68.5	1086	13	489	305	84.7	1342	22	502
2.0	260	72.2	1145	15	505	325	90.3	1431	25	521
2.2	274	76.0	1205	17	519	347	96.4	1528	28	538
2.4	288	80.1	1269	19	533	371	103	1632	32	554
2.6	304	84.4	1338	21	546	396	110	1743	36	571
2.8	321	89.2	1413	23	559	422	117	1860	40	588
3.0	340	94.4	1497	25	574	450	125	1981	45	606
3.2	361	100	1590	27	591	479	133	2107	50	627
3.4	385	107	1695	29	611	508	141	2237	55	650
3.6	412	114	1812	31	635	538	150	2370	60	677
3.8	441	123	1944	33	663	569	158	2505	65	709
4.0	475	132	2091	35	697	600	167	2642	70	746

Flow measurement accuracy using KV-signal

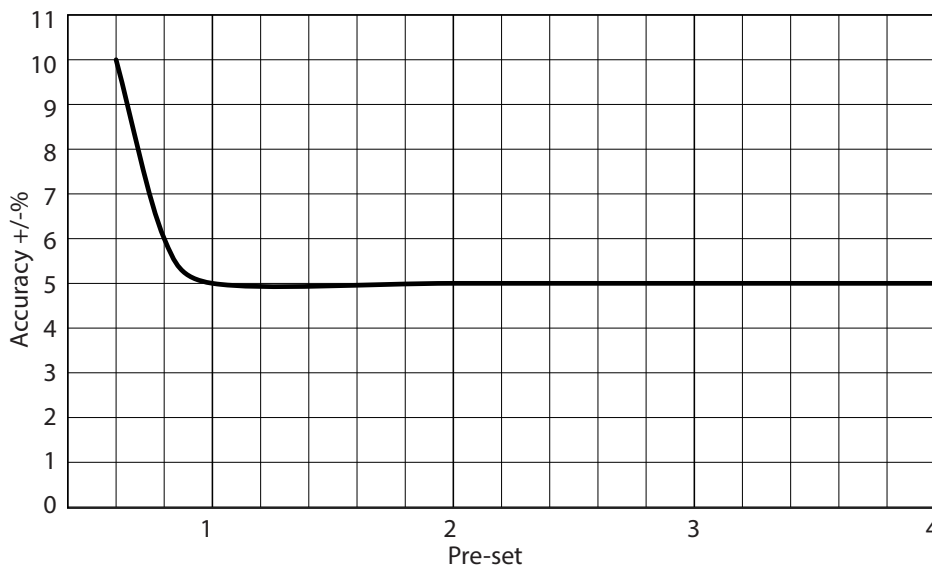

When using the KV-signal for flow measurement, the accuracy is $\pm 5\%$. See the curve to the left.

The curve is applicable regardless of the mounting position of OPTIMA Compact.

The KV-values accuracy follows the BS 7350 standard for flow measurement devices for heating and chilled water systems.

